

Reductions of Young tableau bijections

Igor Pak

Massachusetts Institute of Technology
Cambridge, MA 02138 USA
e-mail: pak@math.mit.edu

and

Ernesto Vallejo

Instituto de Matemáticas, Unidad Morelia, UNAM
Apartado Postal 61-3, Xangari
58089 Morelia, Mich., MEXICO
e-mail: vallejo@matmor.unam.mx

June 23, 2004

Abstract

We introduce notions of linear reduction and linear equivalence of bijections for the purposes of study bijections between Young tableaux. Originating in Theoretical Computer Science, these notions allow us to give a unified view of a number of classical bijections, and establish formal connections between them.

Introduction

Combinatorics of Young tableaux is a beautiful subject which originated in the works of Alfred Young over a century ago, and has been under intense development in the past decades because of its numerous applications [12, 28, 36, 43]. The amazing growth of the literature and a variety of advanced extensions and generalizations led to some confusion even about the classical combinatorial results in the subject. It seems that until now, researchers in the field have not been able to unify the notation, techniques, and systematize their accomplishments.

In this paper we concentrate on bijections between Young tableaux, a classical and the most a combinatorially effective part of subject. The notable bijections include Robinson-Schensted-Knuth correspondence, Jeu de Taquin, Schützenberger involution, Littlewood-Robinson map, and Benkart-Sottile-Stroomer's tableau switching.

The available descriptions of these bijections are so different, that a casual reader receives the impression that all these maps are only vaguely related to each other. Even though there is a number of well-known and important connections between some of these bijections, these results are sporadic and until this work did not fit any general theory. The idea of this paper is to give a formal general approach to positively resolve this problem, and place these bijections under one roof, so to speak.

We introduce new notions of *linear reduction* and *linear equivalence* of bijections, and show that the above mentioned bijections are linearly equivalent. This gives the first rigorous result showing that these bijections are “all the same” in a certain precise sense. A benefit of this approach is that we obtain a number of new properties of Young tableau bijections, establish several unexpected connections between them, and even discover a few “traditional style” conjectures. We elaborate here on the nature and the origin of our approach, while leaving definitions and main results to the next two sections.

The philosophy behind this paper is the basic idea that Young tableau bijections are significantly different from almost all classical bijections in combinatorics, and that a complexity approach captures this difference. On the one hand, the universe of combinatorial bijections is quite heterogenous: some bijections are canonical while some are inherently non-symmetric, some are recursive while some are direct and explicit, some are very natural and easy to find while some are highly nontrivial and their discovery is a testament to human ingenuity (see e.g. [30, 43]). On the other hand, there is a property that almost all of them share and this is that they can be computed in the linear number of steps (see below). This is what explains why proofs of their validity tend to be relatively straightforward, even if bijections’ construction may seem complicated. Similarly, the way bijections transfer combinatorial statistics between sets, tend to be relatively transparent, which accounts for effectiveness of such bijections in the majority of successful applications.

In contrast, Young tableau bijections are substantially harder to establish, their working is delicate and proving their properties is subtle (as is witnessed by the validity of the Jeu de Taquin, the duality of the RSK correspondence, and the many decades that passed before the Littlewood-Robinson correspondence was formally proved). To explain this phenomenon we make two observations. First, we observe that all these bijections are inherently nonlinear and require* roughly $O(N^{3/2})$ number of arithmetic and logical operations (in the size N it takes to encode the tableaux). Second, we show that any of these bijections can be used to construct any other. This explains the identical power $3/2$ in all cases, and at the same time asserts that all these “exceptionally hard” bijections are “essentially the same” and thus form a single class of “counterexamples to the rule” (that all bijections can be computed in linear time). Making these claims rigorous is a difficult task which required the introduction of new

*We do not prove the lower bound, only the upper bound on the time complexity.

notation, definitions, and tools.

Following ideas of Theoretical Computer Science, we view each *bijection* as an algorithm with one type of combinatorial objects as the input, and another as an output. To make a distinction, we say that a *correspondence* is a one-to-one map established (produced) by a bijection. Thus, several different bijections can *define* the same correspondence (cf. [30]). The *complexity*, or the *cost* of the algorithm, is, roughly, the number of steps in the bijection. One can think of a correspondence as a *function* which is computed by the algorithm (a bijection). In contrast with the emphasis in Cryptography, our correspondences (and their inverses!) are relatively easy to compute. On the contrary, the bijections we analyze play an important role in Algebraic Combinatorics in part due to this fact.

Now, as it is the case in Computational Complexity, finding lower bounds for the cost of bijections defining a given correspondence is a hard problem; we do not approach this question in the paper. Instead, we utilize what is known as *Relative Complexity*, an approach based on reduction of combinatorial problems. The reader may recall that the class of NP-complete problems is closed under polynomial time reductions [14]. Similar notions exist for a variety of problems in low complexity classes, with various restrictions on time and space of the algorithms (see e.g. [33]).

In this paper we consider only **linear time reductions**; since the bijections we consider require subquadratic time the reductions have to preserve that. Formally, we say that function f *reduces linearly* to g , if one can compute f in time linear in the time it takes to compute g . We say that f and g are *linearly equivalent* if f reduces linearly to g and vice versa. This defines an equivalence relation on functions; it now can be translated into a linear equivalence on combinatorial bijections.

Our main result is a linear equivalence of the Young tableau bijections mentioned above, as well as few other known and new bijections. To present a (skew, semistandard) Young tableau with $\leq k$ (possibly empty) rows and entries $\leq k$, we need to write $\binom{k+1}{2}$ integers $a_{i,j}$ which represent the number of j 's in i -th row. Ignoring the size of $a_{i,j}$, this gives input of size $O(k^2)$. Now, we shall see that all the bijections described above use the same subquadratic number $O(k^3)$ of arithmetic and logical operations[†]. This is in sharp contrast with the Young tableau bijections of linear cost, defined in the previous paper by the authors [32]. Roughly, we showed there that $O(k^2)$ is the cost of bijections between several combinatorial interpretations of the Littlewood-Richardson's coefficients. This comes from the fact that bijections in [32] are given by simple linear transformations, while Young tableau maps in this paper are inherently nonlinear.

Despite our exhaustive search through the literature, it seems that Computational Complexity has never been used in this area of Algebraic Combinatorics. In fact, we were able to find very few references with any kind of computational approach (see [4, 44] for rare examples). Of course, this is in sharp contrast with other parts of

[†]Taking $N = k^2$ this gives $O(N^{3/2})$ time mentioned above.

Combinatorics such as Graph Theory, Discrete Geometry, or Probabilistic Combinatorics, where computational ideas led to important advances and shift in philosophy. We hope this paper will serve a starting point in the future investigations of complexity of combinatorial bijections.

We now elaborate on the content and the structure of the paper. As the reader will see, this paper is far from being self-contained. In fact, we never even define some of the classical Young tableau bijections and in most proofs we assume that the reader is familiar with the subject. This decision was largely forced upon us, to keep the paper of manageable size. On the other hand, we are careful to include a number of propositions giving properties and often alternative definitions of these bijections. Thus, much of the paper (the nontechnical part) can be read by the reader unfamiliar with the subject, although in this case some of our results may seem unmotivated, inelegant, or even simplistic.

The structure of the paper is unusual as we try to emphasize the results themselves rather than the technical details in the proofs. We start by giving basic definitions and listing the classical maps, in terms of combinatorial objects they act upon (section 1). Even the reader well familiar with the subject is encouraged to quickly go through these to become familiar with our notation. We then present our new framework (of linear reductions) and immediately state main results (Section 2). In Section 3 we present properties of the bijections, connecting them to each other through known results in the literature. Section 4 consists of a number of small subsections which give linear reductions between various pairs of these bijections. This section represents the main part of the proof; proofs of technical lemmas and other details are given in Section 5. In Section 6 we describe several conjectures and other important bijections worthy of analysis. Final remarks are given in Section 7.

We should mention that throughout the first four sections we make no references to the literature. Instead, in Subsection 5.1 we present a very brief overview of the literature together with citation of sources containing the propositions. Further references are given in Section 6.

Notation. We denote partitions by Greek letters: $\lambda, \mu, \nu, \pi, \sigma, \tau, \dots$ while maps are denoted by different Greek letters: $\varphi, \psi, \phi, \zeta, \xi, \rho, \eta, \dots$ Young tableaux are denoted by A, B, C, \dots generic sets of partitions are denoted by $\mathcal{A}, \mathcal{B}, \mathcal{C}, \dots$ and integer arrays (weights of the tableaux) are denoted by $\mathbf{a}, \mathbf{b}, \mathbf{m}, \dots$ All Young diagrams and Young tableaux are presented in English notation [12, 43]. Finally, we use $\mathbb{N} = \{1, 2, \dots\}$ and $\mathbb{Z}_{\geq 0} = \{0, 1, 2, \dots\}$.

We should alert the reader to the fact that we use “*Proposition*” mainly to describe known results, and we reserve “*Theorem*” and “*Lemma*” for the new results.

1 Basic definitions

1.1 Young diagrams and Young tableaux

A *partition* λ is a non-negative integer sequence $(\lambda_1, \dots, \lambda_\ell)$, such that $\lambda_1 \geq \dots \geq \lambda_\ell \geq 0^\ddagger$. Denote by $\ell = \ell(\lambda)$ the number of parts of λ , and let $|\lambda| = \lambda_1 + \dots + \lambda_\ell$. We say that λ is a *partition of* $n = |\lambda|$ and write $\lambda \vdash n$. We represent a partition graphically by a *Young diagram* $[\lambda]$ defined to be a collection of squares $\{(i, j) \in \mathbb{Z}^2 \mid 1 \leq j \leq \lambda_i, 1 \leq i \leq \ell\}$ (see Figure 1). Throughout the paper we often make no distinction between partitions and the corresponding Young diagrams.

We say that $\mu \subset \lambda$ if $\mu_i \leq \lambda_i$ for all $i > 0$. In other words, we have $\mu \subset \lambda$ for partitions whenever $[\mu] \subset [\lambda]$ for Young diagrams viewed as sets of squares (see Figure 1). A *skew Young diagram* $[\lambda/\mu]$ is the shape of a set of squares in $[\lambda] - [\mu]$, where $\mu \subset \lambda$. Let $|\lambda/\mu| = |\lambda| - |\mu|$ denote the number of squares in $[\lambda/\mu]$, and $\ell(\lambda/\mu)$ the height of $[\lambda/\mu]$. Without loss of generality we can always assume that $\ell(\lambda/\mu) = \ell(\lambda)$. We say that a skew Young diagram $[\lambda/\mu]$ is *attached* to a skew Young diagram $[\mu/\nu]$, for all $\nu \subset \mu \subset \lambda$, and denote by $[\lambda/\nu] = [\mu/\nu] \star [\lambda/\mu]$ the union of these two diagrams. For two skew diagrams $[\lambda/\mu]$ and $[\nu/\tau]$ we define a *composition*

$$[\nu/\tau] \circ [\lambda/\mu] := [(\lambda_1 + \nu_1, \dots, \lambda_\ell + \nu_1, \nu_1, \dots, \nu_r) / (\mu_1 + \nu_1, \dots, \mu_\ell + \nu_1, \tau_1, \dots, \tau_r)],$$

where $\ell = \ell(\lambda)$, $r = \ell(\nu)$. Graphically, this corresponds to placing $[\lambda/\mu]$ above and to the right of $[\nu/\tau]$ (see Figure 1). We can generalize this to $[\nu/\tau] \circ_{a,b} [\lambda/\mu]$, where $[\lambda/\mu]$ is shifted by b squares above $[\nu]$ and by a squares to the right of the left margin of $[\nu]$, here $a \geq \nu_1$. Thus, $[\nu/\tau] \circ_{\nu_1, 0} [\lambda/\mu] = [\nu/\tau] \circ [\lambda/\mu]$.

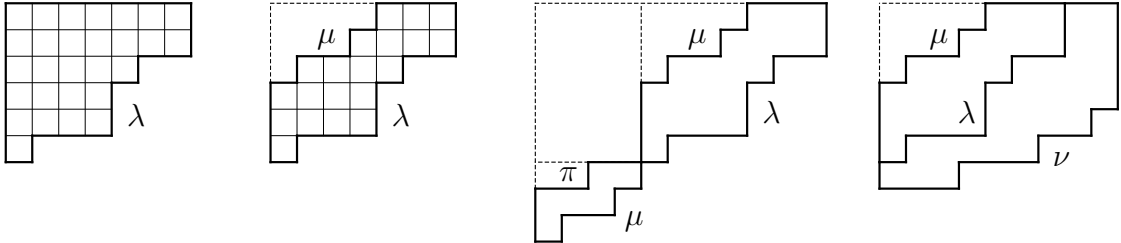

Figure 1: Young diagram $[\lambda]$, and skew Young diagrams $[\lambda/\mu]$, $[\mu/\pi] \circ [\lambda/\mu]$, and $[\lambda/\mu] \star [\nu/\lambda]$, where $\lambda = (7^2 5 4^2 1)$, $\mu = (4 3 1)$, $\nu = (9^4 8 6 3)$, and $\pi = (2)$.

A *Young tableau* A of shape λ/μ is a function $A : [\lambda/\mu] \rightarrow \mathbb{N}$, which is increasing in columns and non-decreasing in rows. We think of the values $A(i, j)$ as being written

[‡]Allowing $\lambda_i = 0$ is more natural from complexity point of view and makes no difference for Young tableau bijections.

in the squares of the (skew) Young diagram (see Figure 2). The *weight* of a tableau A , denoted $\mathbf{weight}(A)$, is a sequence $\mathbf{m} = (m_1, m_2, \dots)$, where $m_r = |\{(i, j) \in [\lambda/\mu] \mid A(i, j) = r\}|$. Clearly, $m_1 + m_2 + \dots = n = |\lambda/\mu|$. Denote by $\ell(\mathbf{m})$ the length of \mathbf{m} and by $\text{YT}(\lambda, \mathbf{m})$ the set of Young tableaux of shape λ and weight \mathbf{m} . In some cases the weight \mathbf{m} will be a partition of n . Let $\text{YT}(\lambda/\mu; k)$ denote the set of Young tableaux of shape λ/μ and weight \mathbf{m} , such that $\ell(\mathbf{m}) \leq k$. In other words, $\text{YT}(\lambda/\mu; k)$ contains all tableaux with integers $\leq k$. By $\text{Can}(\lambda)$ we denote the unique Young tableau $A \in \text{YT}(\lambda, \lambda)$ with 1's in the first row, 2's in the second row, etc. We call such A a *canonical tableau* of shape λ (see Figure 2).

Denote by $A \circ B$ the natural composition of two (skew) Young tableaux. Similarly, denote by $A \star B$ the attachment of two (skew) Young tableaux, whenever this is possible.

For a sequence of integers $\mathbf{i} = (i_1, \dots, i_n)$, $i_r \in \mathbb{N}$, denote by $m_j(\mathbf{i})$ the number of j 's in \mathbf{i} . We say that \mathbf{i} is *positive* if $m_1(\mathbf{i}) \geq m_2(\mathbf{i}) \geq \dots$. Similarly, we say that $\mathbf{i} = (i_1, \dots, i_n)$ is *dominant* if $\mathbf{i}_r = (i_1, \dots, i_r)$ is positive for all $1 \leq r \leq n$. For a Young tableau A denote by $\mathbf{word}(A)$ the sequence obtained by reading right-to-left the first row, then the second row, etc.

We say that A is a *Littlewood-Richardson (LR) tableau* if A is a Young tableau and $\mathbf{word}(A)$ is dominant. Denote by $\text{LR}(\lambda/\mu, \nu)$ the set of all LR-tableaux of shape λ/μ and weight ν . Observe that when $\mu = \emptyset$, there exist only one LR-tableau: a canonical tableau of shape λ and weight $\nu = \lambda$.

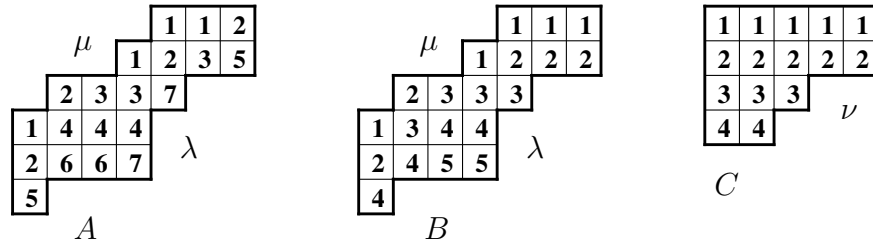

Figure 2: Young tableaux $A \in \text{YT}(\lambda/\mu, \tau)$, $B \in \text{LR}(\lambda/\mu, \sigma)$, and $C = \text{Can}(\nu)$, where $\lambda = (7, 7, 5, 4, 4, 1)$, $\mu = (4, 3, 1)$, $\tau = (4, 4, 3, 3, 2, 2, 2)$, $\sigma = (5, 5, 4, 4, 2)$, and $\nu = (5, 5, 3, 2)$.

To simplify the examples we illustrate the tableaux by diagram drawings. We circle the weight of general Young tableaux, put it in a square in case of LR-tableaux, and put it in a downward triangle for canonical tableaux. See Figure 3 for an illustration of Young tableaux given in Figure 2.

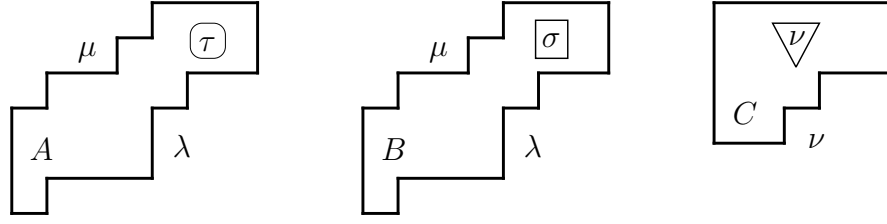

Figure 3: Illustrations of Young tableaux $A \in \text{YT}(\lambda/\mu, \tau)$, $B \in \text{LR}(\lambda/\mu, \sigma)$, and $C = \text{Can}(\nu)$.

1.2 Main bijections

Here we present only the notation and set-theoretic statements of the bijections. These bijections will be further studied in Section 3.

Let $\mathbf{a} = (a_1, \dots, a_k)$, $\mathbf{b} = (b_1, \dots, b_k)$, such that $a_i, b_j \in \mathbb{Z}_{\geq 0}$ and $|\mathbf{a}| = |\mathbf{b}|$, i.e. $a_1 + \dots + a_k = b_1 + \dots + b_k = N$. Denote by $\text{Mat}(\mathbf{a}, \mathbf{b})$ the set of $k \times k$ matrices $V = (v_{i,j})$, such that $v_{i,j} \in \mathbb{Z}_{\geq 0}$ and

$$\sum_{j=1}^k v_{i,j} = a_i, \quad \sum_{i=1}^k v_{i,j} = b_j, \quad \text{for all } 1 \leq i, j \leq k.$$

1) The *Robinson-Schensted-Knuth* (RSK) *correspondence* is a one-to-one correspondence

$$\varphi : \text{Mat}(\mathbf{a}, \mathbf{b}) \longrightarrow \bigcup_{\lambda \vdash N} \text{YT}(\lambda, \mathbf{b}) \times \text{YT}(\lambda, \mathbf{a}),$$

where $|\mathbf{a}| = |\mathbf{b}| = N$ as above. Recall that if $\varphi(V) = (B, A)$, then B is called the *insertion tableau* and A is called the *recording tableau*, that is, B is the P -tableau and A is the Q -tableau.

2) Let $\mu \subset \lambda$ and $\mathbf{a} = (a_1, \dots, a_m)$ be a sequence of non-negative integers such that $n = |\mathbf{a}| = |\lambda/\mu|$. *Jeu de Taquin* is a map

$$\psi : \text{YT}(\lambda/\mu, \mathbf{a}) \longrightarrow \bigcup_{\pi \vdash n} \text{YT}(\pi, \mathbf{a}).$$

We should emphasize that ψ is neither an into nor an onto map. As we shall see later, it plays a central role in the universe of Young tableau bijections.

3) In notation of the *Jeu de Taquin* map, the *Littlewood-Robinson map* is given by the following one-to-one correspondence:

$$\phi : \text{YT}(\lambda/\mu, \mathbf{a}) \longrightarrow \bigcup_{\pi \vdash n} \text{YT}(\pi, \mathbf{a}) \times \text{LR}(\lambda/\mu, \pi).$$

4) Suppose now that $\mu \subset \lambda$ and \mathbf{c}, \mathbf{d} are sequences of non-negative integers such that $n = |\lambda/\mu| = |\mathbf{c}| + |\mathbf{d}|$. *Tableau Switching* is a one-to-one correspondence:

$$\zeta : \bigcup_{\pi \vdash |\lambda| - |\mathbf{c}|} \text{YT}(\pi/\mu, \mathbf{d}) \times \text{YT}(\lambda/\pi, \mathbf{c}) \longrightarrow \bigcup_{\sigma \vdash |\lambda| - |\mathbf{d}|} \text{YT}(\sigma/\mu, \mathbf{c}) \times \text{YT}(\lambda/\sigma, \mathbf{d}).$$

4') We shall need a special notation for *Tableau Switching* in case μ is the empty partition, that is for *normal shapes*:

$$\zeta^{\mathbf{N}} : \bigcup_{\pi \vdash |\mathbf{d}|} \text{YT}(\pi, \mathbf{d}) \times \text{YT}(\lambda/\pi, \mathbf{c}) \longrightarrow \bigcup_{\sigma \vdash |\mathbf{c}|} \text{YT}(\sigma, \mathbf{c}) \times \text{YT}(\lambda/\sigma, \mathbf{d}).$$

5) Let $\mathbf{a} = (a_1, \dots, a_m)$ be an integer sequence, such that $|\mathbf{a}| = |\lambda/\mu|$. Consider a sequence $\mathbf{a}^* := (a_m, \dots, a_1)$. Clearly, $|\mathbf{a}^*| = |\lambda/\mu|$ as well. The *Schützenberger involution* is a one-to-one correspondence:

$$\xi : \text{YT}(\lambda/\mu, \mathbf{a}) \rightarrow \text{YT}(\lambda/\mu, \mathbf{a}^*).$$

5') We shall also need a special notation for the Schützenberger involution for *normal shapes*:

$$\xi^{\mathbf{N}} : \text{YT}(\lambda, \mathbf{a}) \rightarrow \text{YT}(\lambda, \mathbf{a}^*).$$

6) There is a different one-to-one correspondence of the same kind as ξ called *reversal*:

$$\chi : \text{YT}(\lambda/\mu, \mathbf{a}) \rightarrow \text{YT}(\lambda/\mu, \mathbf{a}^*).$$

This correspondence has certain advantages over the Schützenberger involution, and will be useful for the proofs.

7), 8) Finally, suppose $\nu \vdash |\lambda/\mu|$. The *Fundamental Symmetry* is a one-to-one correspondence:

$$\rho : \text{LR}(\lambda/\mu, \nu) \rightarrow \text{LR}(\lambda/\nu, \mu).$$

In this paper we define several versions of the *Fundamental Symmetry* map, and the main results cover the *First* and the *Second Fundamental Symmetry* maps. In general, we say that a map *gives the Fundamental Symmetry map* if it is a one-to-one correspondence between sets as above.

1.3 Computational preliminaries

Let $D = (d_1, \dots, d_n)$ be an array of integers, and let $m = m(D) := \max_i d_i$. The *bit-size* of D , denoted by $\langle D \rangle$, is the amount of space required to store D . For simplicity everywhere below we assume that $\langle D \rangle = n \lceil \log_2 m + 1 \rceil$.

We view a bijection $\tau : \mathcal{A} \rightarrow \mathcal{B}$ as an algorithm which inputs $A \in \mathcal{A}$ and outputs $B = \tau(A) \in \mathcal{B}$. We need to present Young tableaux as arrays of integers so that we can store them and compute their bit-size.

Suppose $A \in \text{YT}(\lambda/\mu; k)$. An important way to encode A is through a matrix, often called the *Gelfand-Tsetlin (GT) pattern* $(a_{i,j})$ of the tableau, whose entries satisfy certain inequalities which are irrelevant for the purposes of this paper. It is defined by $a_{i,0} = \mu_i$ and $a_{i,j} = \mu_i +$ the number of integers in row i which are $\leq j$, for $1 \leq i \leq \ell(\lambda/\mu)$ and $1 \leq j \leq k$. The tableau A can be now be viewed as a matrix $(a_{i,j})$; this is the way Young tableaux will be presented in the input and output of the algorithms. Another useful way to encode A is through its *recording matrix* $(c_{i,j})$, which is defined by $c_{i,j} = a_{i,j} - a_{i,j-1}$; in other words, $c_{i,j}$ is the number of j 's in the i -th row of A .

Finally, we say that a map $\gamma : \mathcal{A} \rightarrow \mathcal{B}$ is *size-neutral* if the ratio $\langle \gamma(A) \rangle / \langle A \rangle$ is bounded for all $A \in \mathcal{A}$. Throughout the paper we consider only size-neutral maps, often without emphasizing it. See the remark following Theorem 2 (Section 2.2) on the reasoning behind this definition.

2 Reductions of bijections and main results

2.1 Linear reductions

Think of a *bijection*, or any *explicit map* in general, as an algorithm with input and output written as an array of integers. Hereafter by *size* of the input/output we mean bit-size. As before, let $\langle A \rangle$ denote the bit-size of the integer array A . We also say that a bijection or an explicit map *defines* a correspondence between input and output set. Clearly, many different bijections can define the same one-to-one correspondence.

Let \mathcal{A} and \mathcal{B} be two possibly infinite sets of finite integer arrays, and let $\delta : \mathcal{A} \rightarrow \mathcal{B}$ be an explicit map between them. We say that δ has *linear cost* if δ computes $\delta(A) \in \mathcal{B}$ in *linear time* $O(\langle A \rangle)$ for all $A \in \mathcal{A}$.

There are many ways to construct new bijections out of existing ones. We call such algorithms *circuits* and define below several of them that we need.

1) Suppose $\delta_1 : \mathcal{A} \rightarrow \mathcal{X}_1$, $\gamma : \mathcal{X}_1 \rightarrow \mathcal{X}_2$ and $\delta_2 : \mathcal{X}_2 \rightarrow \mathcal{B}$, such that δ_1 and δ_2 have linear cost. Consider $\chi = \delta_2 \circ \gamma \circ \delta_1 : \mathcal{A} \rightarrow \mathcal{B}$. We call this circuit *trivial* and denote it by $I(\delta_1, \gamma, \delta_2)$.

2) Suppose $\gamma_1 : \mathcal{A} \rightarrow \mathcal{X}$, $\gamma_2 : \mathcal{X} \rightarrow \mathcal{B}$, and let $\chi = \gamma_2 \circ \gamma_1 : \mathcal{A} \rightarrow \mathcal{B}$. We call this circuit *sequential* and denote it by $S(\gamma_1, \gamma_2)$.

3) Suppose $\delta_1 : \mathcal{A} \rightarrow \mathcal{X}_1 \times \mathcal{X}_2$, $\gamma_1 : \mathcal{X}_1 \rightarrow \mathcal{Y}_1$, $\gamma_2 : \mathcal{X}_2 \rightarrow \mathcal{Y}_2$, and $\delta_2 : \mathcal{Y}_1 \times \mathcal{Y}_2 \rightarrow \mathcal{B}$, such that that δ_1 and δ_2 have linear cost. Consider $\chi = \delta_2 \circ (\gamma_1 \times \gamma_2) \circ \delta_1 : \mathcal{A} \rightarrow \mathcal{B}$. We call this circuit *parallel* and denote it by $P(\delta_1, \gamma_1, \gamma_2, \delta_2)$.

Fix a bijection β . We say that \mathfrak{J} is a β -based *ps-circuit* if one of the following holds:

- $\mathfrak{J} = \delta$, where δ has linear cost.
- $\mathfrak{J} = I(\delta_1, \beta, \delta_2)$.
- $\mathfrak{J} = P(\delta_1, \gamma_1, \gamma_2, \delta_2)$, where γ_1, γ_2 are β -based ps-circuits.
- $\mathfrak{J} = S(\gamma_1, \gamma_2)$, where γ_1, γ_2 are β -based ps-circuits.

In other words, \mathfrak{J} is a β -based ps-circuit if there is a parallel-sequential algorithm which uses only a finite number of linear cost maps and a finite number of maps β . The β -cost of \mathfrak{J} is the number of times the map β is used; we denote it by $\mathbf{s}(\mathfrak{J})$.

Let $\gamma : \mathcal{A} \rightarrow \mathcal{B}$ be a map produced by the β -based ps-circuit \mathfrak{J} . We say that \mathfrak{J} computes γ at cost $\mathbf{s}(\mathfrak{J})$ of β .

We say that a map α is *linearly reducible* to β , write $\alpha \hookrightarrow \beta$, if there exist a finite β -based ps-circuit \mathfrak{J} which computes α . In this case we say that α can be computed in at most $\mathbf{s}(\mathfrak{J})$ cost of β .

We say that maps α and β are *linearly equivalent*, write $\alpha \sim \beta$, if α is linearly reducible to β , and β is linearly reducible to α .

2.2 Main results

Our first result is the linear equivalence of Young tableau bijections given in Section 1.2.

Theorem 1. *The following maps are linearly equivalent:*

- 1) *RSK map φ .*
- 2) *Jeu de Taquin map ψ .*
- 3) *Littlewood-Robinson map ϕ .*
- 4) *Tableau Switching map ζ .*
- 5) *Schützenberger involution for normal shapes ξ^N .*
- 6) *Reversal χ .*
- 7) *First Fundamental Symmetry map ρ_1 .*
- 8) *Second Fundamental Symmetry map ρ_2 .*

Moreover, each of these maps can be computed in at most 36 times the cost of any other map.

The following theorem gives a positive result about the efficient computation of maps 1) – 8).

Theorem 2. *For the eight maps 1) – 8) as in Theorem 1, let k and m be defined as follows:*

$$\begin{array}{ll}
1) & k := \max\{\ell(\mathbf{a}), \ell(\mathbf{b})\}, \quad m := \max\{\sum_i a_i, \sum_j b_j\}, \\
2), 3), 5), 6) & k := \ell(\mathbf{a}), \quad m := \lambda_1, \\
4) & k := \max\{\ell(\mathbf{c}), \ell(\mathbf{d})\}, \quad m := \lambda_1, \\
7), 8) & k := \ell(\nu), \quad m := \lambda_1.
\end{array}$$

Then the image of maps 1) – 8) can be computed at a cost of $O(k^3 \log m)$.

We should emphasize that the standard definitions of these maps give a weaker result. For example, Jeu de Taquin as defined in the literature (see e.g. [36, 43]) requires $O(|\mu| \cdot |\lambda/\mu|)$ square moves, much greater than the bound above.

Remark 1. It may seem that by Theorem 1, it suffices to establish the efficient computation of any one of the maps. This is not the case since we compare the maps by the number of times other maps are used, not by the timing. A priori it can (and does) happen that the maps increase the bit-size of combinatorial objects, when they transform the input into the output. This affects the timing of the subsequent applications of these maps. To control this, we show that all maps we consider are in fact size-neutral, so Theorem 1 remains applicable in this case. We formalize this observation in Section 5.4; for now we suggest the reader simply views linear reductions as if they were reductions on the time complexity of the maps.

3 Properties of bijections

3.1 Bender-Knuth transformations

Define *Bender-Knuth* (BK) *transformations* s_1, s_2, \dots as follows. Consider a Young tableau $A \in \text{YT}(\lambda/\mu, \mathbf{a})$. Let $m = \ell(\mathbf{a})$ be the length of \mathbf{a} , and let $(a_{i,j})$ be the corresponding GT-pattern. For any $1 \leq r < m$, let $B = s_r(A)$ be a Young tableau such that the corresponding GT-pattern $(b_{i,j})$ is defined as follows:

$$b_{i,j} = \begin{cases} \min\{a_{i,r+1}, a_{i-1,r-1}\} + \max\{a_{i,r-1}, a_{i+1,r+1}\} - a_{i,r}, & \text{if } j = r, \\ a_{i,j}, & \text{otherwise.} \end{cases}$$

Observe that BK-transformations are defined by bijections

$$s_i : \text{YT}(\lambda/\mu, \mathbf{a}) \rightarrow \text{YT}(\lambda/\mu, \mathbf{a}'), \quad s_i : A \mapsto B,$$

where $\mathbf{a} = (a_1, \dots, a_i, a_{i+1}, \dots, a_m)$, and $\mathbf{a}' = (a_1, \dots, a_{i+1}, a_i, \dots, a_m)$. They also satisfy the following relations:

$$(\diamond) \quad s_i^2 = 1, \quad s_i s_j = s_j s_i, \quad \text{if } |i - j| \geq 2.$$

Now define elements $t_{r,m-r}$ and z_m as follows:

$$z_m = (s_1)(s_2 s_1)(s_3 s_2 s_1) \cdots (s_{m-1} \cdots s_2 s_1),$$

$$t_{r,m-r} = (s_{m-r} s_{m-r+1} \cdots s_{m-1}) \cdots (s_2 s_3 \cdots s_{r+1})(s_1 s_2 \cdots s_r),$$

where $1 \leq r < m$. By definition,

$$z_m : \text{YT}(\lambda/\mu, \mathbf{a}) \rightarrow \text{YT}(\lambda/\mu, \mathbf{a}^*), \quad t_{r,m-r} : \text{YT}(\lambda/\mu, \mathbf{a}) \rightarrow \text{YT}(\lambda/\mu, \mathbf{b}),$$

where $\mathbf{a}^* = (a_m, \dots, a_{r+1}, a_r, \dots, a_1)$, and $\mathbf{b} = (a_{r+1}, \dots, a_m, a_1, \dots, a_r)$. The maps satisfy the following well-known relations:

$$(\boxtimes) \quad z_m^2 = 1, \quad t_{r, m-r} t_{m-r, r} = 1.$$

We shall also need the following relation:

$$(\otimes) \quad z_{l+k} = z_k t_{l, k} z_l.$$

It will be proved in Section 5.2.

Proposition 1. *The Schützenberger involution map ξ coincides with the map z_m defined as above: $\xi = z_m$.*

Let $\mu \subset \pi \subset \lambda$ be partitions and \mathbf{c}, \mathbf{d} be vectors of non-negative integers such that $|\lambda/\mu| = |\mathbf{c}| + |\mathbf{d}|$. Denote $r = \ell(\mathbf{d})$ and $m = \ell(\mathbf{c}) + \ell(\mathbf{d})$. Let $A \in \text{YT}(\lambda/\pi, \mathbf{c})$, $B \in \text{YT}(\pi/\mu, \mathbf{d})$. Let \tilde{A} denote the tableau obtained from A by adding r to each entry of A . Denote $\mathbf{e} = (c_1, \dots, c_{m-r}, d_1, \dots, d_r)$ and $\mathbf{f} = (d_1, \dots, d_r, c_1, \dots, c_{m-r})$. Consider $B \star \tilde{A} \in \text{YT}(\lambda/\mu, \mathbf{f})$; thus, $t_{r, m-r}(B \star \tilde{A}) \in \text{YT}(\lambda/\mu, \mathbf{e})$. Decompose this tableau as $A' \star \tilde{B}$ with $A' \in \text{YT}(\sigma/\mu, \mathbf{c})$, for some partition σ of $|\mu| + |\mathbf{c}|$, and $\tilde{B} \in \text{YT}(\lambda/\sigma)$. Let B' be obtained from \tilde{B} by subtracting $m - r$ to each one of its entries, so that $B' \in \text{YT}(\lambda/\sigma, \mathbf{d})$. Finally, let $\tilde{t}_{r, m-r}(B, A) = (A', B')$.

Proposition 2. *The Tableau Switching map ζ coincides with the map $\tilde{t}_{r, m-r}$ defined as above.*

3.2 Jeu de Taquin is everywhere

Consider the RSK map first. Let $\varphi : V \mapsto (B, A)$, where $V = (v_{i,j}) \in \text{Mat}(\mathbf{a}, \mathbf{b})$, and $\ell(\mathbf{a}) = \ell(\mathbf{b}) = k$. Define $[\pi/\sigma] = [a_1] \circ [a_2] \circ \dots \circ [a_k]$ and $[\rho/\tau] = [b_1] \circ [b_2] \circ \dots \circ [b_k]$.

Proposition 3. *Let Y be the Young tableau in $\text{YT}(\pi/\sigma, \mathbf{b})$ that has exactly $v_{i,j}$ entries equal to j in row $(k+1) - i$. Then, for the Jeu de Taquin map ψ , one has $\psi(Y) = B$. Similarly, if X is the Young tableau in $\text{YT}(\rho/\tau, \mathbf{a})$ that has exactly $v_{j,i}$ entries equal to j in row $(k+1) - i$. Then $\psi(X) = A$.*

Let $A \in \text{YT}(\lambda/\pi, \mathbf{a})$, $B \in \text{YT}(\pi, \mathbf{b})$. Denote by $(A', B') = \zeta^N(B, A)$ their tableau switching, where $A' \in \text{YT}(\sigma, \mathbf{a})$, $B' \in \text{YT}(\lambda/\sigma, \mathbf{b})$ for some $\sigma \vdash |\lambda/\pi|$.

Proposition 4. *In the notation above, the image (A', B') of (B, A) under the Tableau Switching map ζ satisfies $A' = \psi(A)$.*

One can obtain the Jeu de Taquin map ψ as a projection of the Littlewood-Robinson map ϕ onto the first component.

Proposition 5. *Let the image of the Littlewood-Robinson map $\phi(A) = (B, C)$. Then $\psi(A) = B$.*

Let $[\lambda]$ be Young diagram, and let $[r^\ell]$ be the smallest size rectangle containing $[\lambda]$, i.e. $\ell = \ell(\lambda)$ and $r = \lambda_1$. Denote by $[\lambda^\bullet]$ a skew Young diagram $[r^\ell / (r - \lambda_\ell, \dots, r - \lambda_1)]$. If $A \in \text{YT}(\lambda, \mathbf{a})$ is a Young tableau corresponding to a recording matrix $C = (c_{i,j})$, let $A^\bullet \in \text{YT}(\lambda^\bullet, \mathbf{a}^*)$ by a tableau corresponding to a recording matrix $C^\bullet = (c_{\ell+1-i, k+1-j})$.

Proposition 6. *The image of the Schützenberger involution map $\xi^N(A)$ coincides with the image $\psi(A^\bullet)$.*

Note that Propositions 4 and 6 do not have natural extensions to skew Young diagrams.

3.3 Hidden symmetries of RSK

The first hidden symmetry is called *duality* and has already been used in Proposition 3.

Proposition 7. *Suppose $\varphi(V) = (B, A)$. Then $\varphi(V') = (A, B)$, where V' is the transpose matrix of V .*

The second symmetry is as classical as duality but not as well-known. For any $V = (v_{i,j}) \in \text{Mat}(\mathbf{a}, \mathbf{b})$ of size $k \times k$ we denote $V^* := (v_{k+1-i, k+1-j}) \in \text{Mat}(\mathbf{a}^*, \mathbf{b}^*)$.

Proposition 8. *In the notation above, suppose $\varphi(V) = (B, A)$. Then $\varphi(V^*) = (\xi(B), \xi(A))$.*

3.4 First Fundamental Symmetry map

We start with the following important characterization of Littlewood-Richardson (LR) tableaux:

Proposition 9. *Suppose $A \in \text{YT}(\lambda/\mu, \nu)$. Then A is a LR-tableau if and only if $\psi(A)$ is the canonical tableau $\text{Can}(\nu)$.*

Now we are ready to define the *First Fundamental Symmetry map* ρ_1 . Let $A \in \text{YT}(\lambda/\mu, \nu)$, and let $B = \text{Can}(\mu)$. Consider $(A', B') = \zeta(B, A)$, where $A' \in \text{YT}(\sigma, \nu)$, $B' \in \text{YT}(\lambda/\sigma, \mu)$ for some $\sigma \vdash |\lambda/\mu|$. Define $\rho_1(A) = B'$. By Propositions 4 and 9, if $A \in \text{LR}(\lambda/\mu, \nu)$, we have $A' = \text{Can}(\sigma)$, and therefore $\nu = \sigma$. Similarly, since $B = \text{Can}(\mu)$, by the involution property (\boxtimes) of the tableau switching, we have $B' \in \text{LR}(\lambda/\nu, \mu)$ and $\rho_1^2 = 1$.

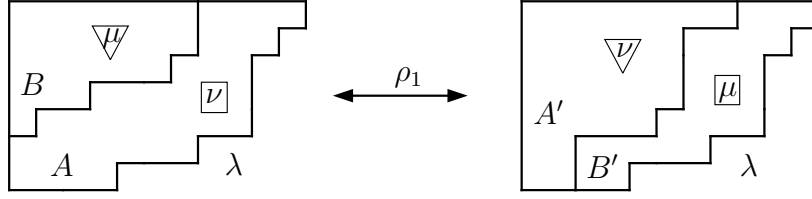

Figure 4: Illustration of $\rho_1 : A \rightarrow B'$, where $A \in \text{LR}(\lambda/\mu, \nu)$, $B' \in \text{LR}(\lambda/\nu, \mu)$.

Proposition 10. *The map ρ_1 is well defined and gives a fundamental symmetry map.*

We define the Littlewood-Robinson map ϕ as follows: Let $A \in \text{YT}(\lambda/\mu, \mathbf{a})$ and $B = \text{Can}(\mu)$. Consider $(A', B') = \zeta(B, A)$, then $A' \in \text{YT}(\sigma, \mathbf{a})$ for some $\sigma \vdash |\lambda/\mu|$. Moreover, by Propositions 4, 9 and the involution property (\boxtimes), $B' \in \text{LR}(\lambda/\sigma, \mu)$. Now, let $C = \text{Can}(\sigma)$ and $(B'', C') = \zeta(C, B')$. Since $B' \in \text{LR}(\lambda/\sigma, \mu)$, we have $B'' = B = \text{Can}(\mu)$ and therefore $C' \in \text{YT}(\lambda/\mu, \sigma)$. Similarly, since $C = \text{Can}(\sigma)$, we have $C' \in \text{LR}(\lambda/\mu, \sigma)$. Finally, let $\phi(A) = (A', C')$. Observe that (A', C') is in $\bigcup_{\pi} \text{YT}(\pi, \mathbf{a}) \times \text{LR}(\lambda/\mu, \pi)$, as desired (see Figure 5).

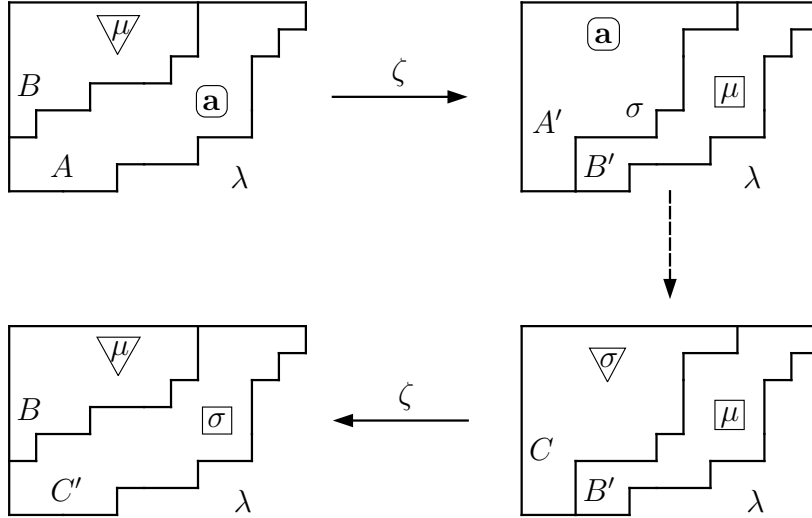

Figure 5: Illustration of $\phi : A \rightarrow (A', C')$, where $A \in \text{YT}(\lambda/\mu, \mathbf{a})$, $A' \in \text{YT}(\sigma, \mathbf{a})$, and $C' \in \text{LR}(\lambda/\mu, \sigma)$, for some $\sigma \vdash |\lambda/\mu|$.

We summarize:

Proposition 11. *The map ϕ is a well defined bijection.*

3.5 Second Fundamental Symmetry map

We define $\rho_2 : \text{LR}(\lambda/\mu, \nu) \rightarrow \text{LR}(\lambda/\nu, \mu)$ as the composition of two linear maps, γ and τ , with the Schützenberger involution ξ . For this we need to introduce some notation. Given partitions λ, μ, ν , such that $|\lambda| = |\mu| + |\nu|$, we define

$$\text{CF}(\mu, \nu, \lambda) = \{B \in \text{YT}(\mu, \lambda - \nu) \mid B \circ \text{Can}(\nu) \in \text{LR}(\mu \circ \nu, \lambda)\},$$

$$\text{CF}^*(\mu, \nu, \lambda) = \{B \in \text{YT}(\mu, (\lambda - \nu)^*) \mid B^\bullet \circ \text{Can}(\nu) \in \text{LR}(\mu^\bullet \circ \nu, \lambda)\}.$$

Now the map

$$\gamma : \text{LR}(\lambda/\mu, \nu) \rightarrow \text{CF}^*(\mu, \nu, \lambda)$$

is defined as follows.

Let $A \in \text{LR}(\lambda/\mu, \nu)$ be a LR-tableau with recording matrix $C = (c_{i,j})$, that is, $c_{i,j}$ is the number of j 's in the i -th row; set also, $c_{0,0} = 0$, $c_{i,0} = \mu_i$ for $1 \leq i \leq l = \ell(\lambda)$ and $c_{k,j} = 0$ for $k > l$. Define $A' = \gamma(A)$ to be the tableau with recording matrix $D = (d_{i,j})$, where

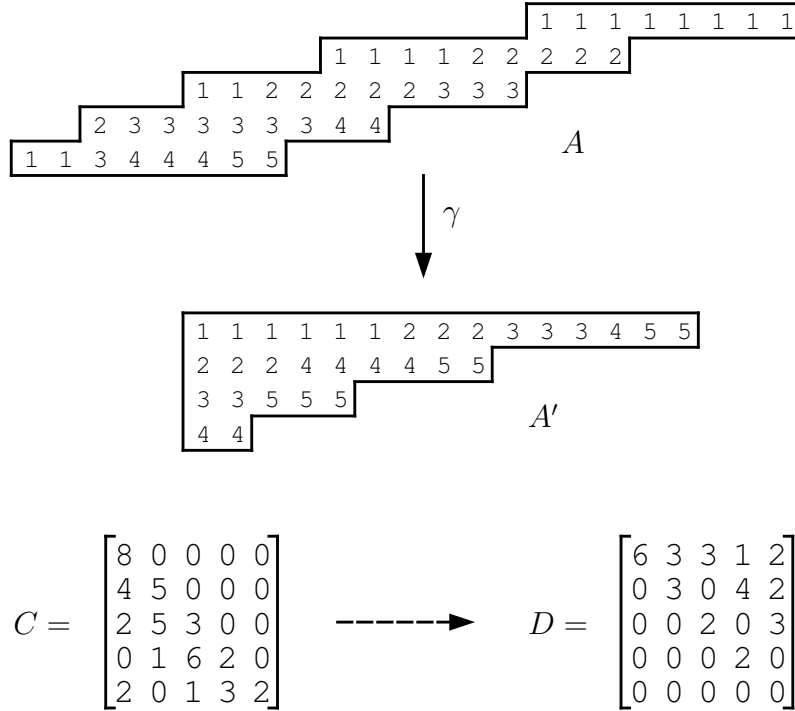

Figure 6: Example of a LR-tableau $A \in \text{LR}(\lambda/\mu, \nu)$, the corresponding tableau $A' = \gamma(A) \in \text{CF}^*(\mu, \nu, \lambda)$, and their recording matrices C and D . Here $\lambda = (23, 18, 15, 11, 8)$, $\mu = (15, 9, 5, 2, 0)$, and $\nu = (16, 11, 10, 5, 2)$.

$$d_{i,j} = \sum_{q=0}^{l-j} c_{l-j+i,q} - \sum_{q=0}^{l-j+1} c_{l-j+1+i,q}.$$

An example is given in Figure 6.

Proposition 12. *The map γ is a well defined bijection.*

The map

$$\tau : \text{LR}(\lambda/\mu, \nu) \rightarrow \text{CF}(\nu, \mu, \lambda)$$

is defined as follows: Let $A \in \text{LR}(\lambda/\mu, \nu)$ be a tableau with recording matrix $C = (c_{i,j})$. Define $\tau(A)$ to be the tableau with recording matrix $E = (e_{i,j})$, where $e_{i,j} = c_{j,i}$, for $1 \leq i \leq j \leq l$.

Proposition 13. *The map τ is a well defined bijection.*

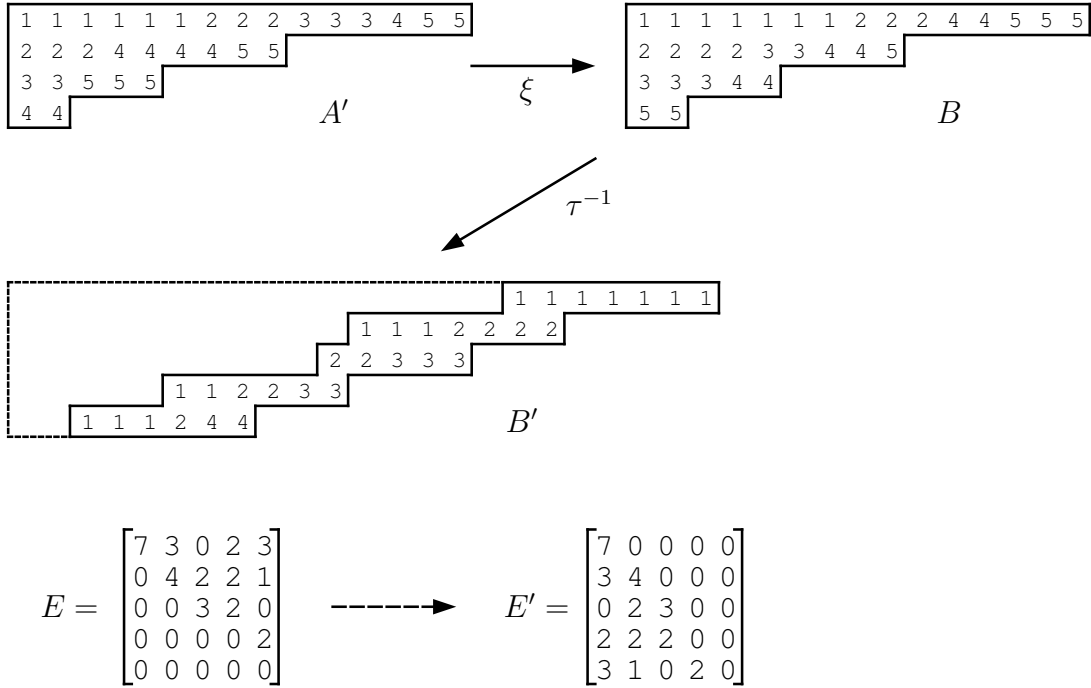

Figure 7: Example of the Schützenberger involution $\xi : A' \mapsto B$ and the map $\tau^{-1} : B \mapsto B'$, and the recording matrices E, E' of the Young tableaux B, B' . Here $A' \in \text{CF}^*(\mu, \nu, \lambda)$, $B \in \text{CF}(\mu, \nu, \lambda)$, and $B' \in \text{LR}(\lambda/\nu, \mu)$, where λ, μ, ν as in Figure 6.

The map ρ_2 is defined as the composition $\rho_2 := \tau^{-1} \circ \xi^N \circ \gamma$. A similar fundamental symmetry map can be defined as the its inverse: $\rho_2' := \rho_2^{-1} = \gamma^{-1} \circ \xi^N \circ \tau$.

Proposition 14. *The maps ρ_2 and ρ_2' are fundamental symmetry maps.*

Note that, by Proposition 6 and the involution property (\boxtimes), the restriction of the Schützenberger involution defines a bijection $\xi^N : \text{CF}^*(\mu, \nu, \lambda) \rightarrow \text{CF}(\mu, \nu, \lambda)$. This, together with Propositions 12 and 13 imply Proposition 14.

We conjecture in Section 6.1 that ρ_1 in fact coincides with ρ_2 and with ρ_2' . In the absence of this result we use a different argument to prove linear equivalence of these maps and the remaining maps in Theorem 1.

3.6 Reversal

We define reversal as the *conjugation* of Schützenberger involution with tableau switching $\chi = \zeta \circ \xi \circ \zeta$. More precisely, let $A \in \text{YT}(\lambda/\mu, \mathbf{a})$ and denote $C = \text{Can}(\mu)$. Consider $(A', C') = \zeta(C, A)$ and $(C'', A'') = \zeta(\xi(A'), C')$. Then, by Propositions 4, 9 and the involution property (\boxtimes), $C'' = \text{Can}(\mu)$, and therefore $A'' \in \text{YT}(\lambda/\mu, \mathbf{a}^*)$. Reversal is defined by $\chi(A) := A''$ (see Figure 8).

Proposition 15. *The map χ is a well defined involution.*

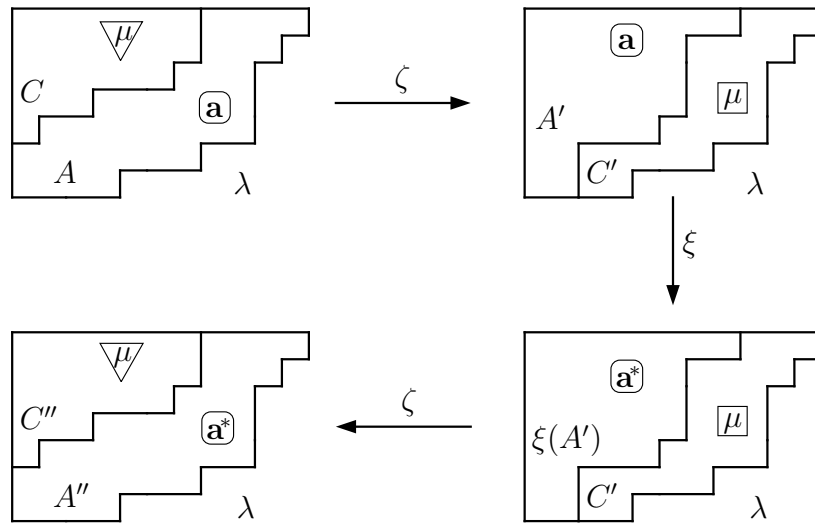

Figure 8: Illustration of $\chi : A \mapsto A''$, where $A \in \text{YT}(\lambda/\mu, \mathbf{a})$, $A'' \in \text{YT}(\lambda/\mu, \mathbf{a}^*)$.

4 Collection of linear reductions

4.1 Outline of the proof of Theorem 1

Following definitions, we would have to present $8 \cdot 7 = 56$ different linear reductions to prove Theorem 1. In fact, as will be shown in the next section, linear equivalence is an equivalence relation, so only $2 \cdot (8 - 1) = 14$ linear reductions suffice (say, between φ and all other maps). Some of these reductions are quite difficult, while the proof can be obtained by a smaller number of easier reductions. The latter follows a less obvious pattern summarized in the following lemma.

Recall that $\alpha \hookrightarrow \beta$ stands for the map α linearly reducible to the map β .

Main Lemma *For the maps as in Theorem 1, the following linear reductions hold:*

- $\varphi \hookrightarrow \psi \hookrightarrow \phi \hookrightarrow \zeta^N \hookrightarrow \xi^N \hookrightarrow \varphi$,
- $\rho_1 \hookrightarrow \zeta^N \hookrightarrow \zeta \hookrightarrow \rho_1$ and $\rho_2 \hookrightarrow \xi^N \hookrightarrow \rho_2$,
- $\chi \hookrightarrow \xi^N \hookrightarrow \chi$.

In the next subsection we show that the Main Lemma implies the first part of Theorem 1. The rest of the section will contain the proof of linear reductions in the Main Lemma.

4.2 Compositions of linear reductions

We start with the following elementary but very useful results, which simplify the proof of Theorem 1. While these results are standard in Computer Science, they have never appeared in this context. We present short straightforward proofs for completeness.

Composition Lemma *Suppose $\alpha_1 \hookrightarrow \alpha_2$ and $\alpha_2 \hookrightarrow \alpha_3$. Then $\alpha_1 \hookrightarrow \alpha_3$. Moreover, if α_1 can be computed in at most s_1 cost of α_2 , and α_2 can be computed in at most s_2 cost of α_3 , then α_1 can be computed in at most $(s_1 s_2)$ cost of α_3 .*

Proof. Suppose \mathfrak{J}_1 is a α_2 -based ps-circuit which computes α_1 , and \mathfrak{J}_2 is a α_3 -based ps-circuit which computes α_2 . Substitute each of the $\mathbf{s}(\mathfrak{J}_1)$ maps α_2 in circuit \mathfrak{J}_1 with the circuit \mathfrak{J}_2 . Denote the resulting circuit by \mathfrak{J} . By definition, \mathfrak{J} is a α_3 -based ps-circuit computing α_1 . Observe also that α_3 is used $\mathbf{s}(\mathfrak{J}_2)$ times in each copy of \mathfrak{J}_2 , and thus α_3 is used $\mathbf{s}(\mathfrak{J}_1)\mathbf{s}(\mathfrak{J}_2)$ times in \mathfrak{J} . This implies the result. \square

Corollary 1. *Suppose $\alpha_1 \sim \alpha_2$ and $\alpha_2 \sim \alpha_3$. Then $\alpha_1 \sim \alpha_3$.*

Proof. By definition of linear equivalence, we have $\alpha_1 \hookrightarrow \alpha_2 \hookrightarrow \alpha_3$. Now the Composition Lemma implies $\alpha_1 \hookrightarrow \alpha_3$. Similarly, $\alpha_3 \hookrightarrow \alpha_2 \hookrightarrow \alpha_1$, which implies $\alpha_3 \hookrightarrow \alpha_1$. We conclude $\alpha_1 \sim \alpha_3$. \square

Corollary 2. (Cycle Lemma) *Suppose $\alpha_1 \hookrightarrow \alpha_2 \hookrightarrow \dots \hookrightarrow \alpha_n \hookrightarrow \alpha_1$. Then $\alpha_1 \sim \alpha_2 \sim \dots \sim \alpha_n$.*

Proof. For every $1 \leq i < j \leq n$ we have $\alpha_i \hookrightarrow \alpha_{i+1} \hookrightarrow \dots \hookrightarrow \alpha_j$ and

$$\alpha_j \hookrightarrow \alpha_{j+1} \hookrightarrow \dots \hookrightarrow \alpha_n \hookrightarrow \alpha_1 \hookrightarrow \alpha_2 \hookrightarrow \dots \hookrightarrow \alpha_i.$$

By Composition Lemma, this implies $\alpha_i \hookrightarrow \alpha_j$ and $\alpha_j \hookrightarrow \alpha_i$, and thus $\alpha_i \sim \alpha_j$. \square

Corollary 3. *Main Lemma implies the first part of Theorem 1.*

Proof. By Cycle Lemma, we have $\varphi \sim \psi \sim \phi \sim \zeta^N \sim \xi^N$. These equivalences, $\rho_1 \sim \zeta^N \sim \zeta$, $\rho_2 \sim \xi^N$, $\chi \sim \xi^N$ and Corollary 1 prove the claim. \square

4.3 Reduction $\varphi \hookrightarrow \psi$

The linear reduction of the RSK map φ to the Jeu de Taquin map ψ follows from Proposition 3. Below we present the corresponding ψ -based ps-circuit proving $\varphi \hookrightarrow \psi$.

- ◊ Input $k, \mathbf{a}, \mathbf{b}$, such that $\ell(\mathbf{a}), \ell(\mathbf{b}) \leq k$.
- ◊ Input $V = (v_{i,j}) \in \text{Mat}(\mathbf{a}, \mathbf{b})$.
- ◊ Set $\pi := (a_1 + \dots + a_k, a_1 + \dots + a_{k-1}, \dots, a_1)$.
- ◊ Set $\sigma := (a_1 + \dots + a_{k-1}, a_1 + \dots + a_{k-2}, \dots, a_1, 0)$.
- ◊ Set $\rho := (b_1 + \dots + b_k, b_1 + \dots + b_{k-1}, \dots, b_1)$.
- ◊ Set $\tau := (b_1 + \dots + b_{k-1}, b_1 + \dots + b_{k-2}, \dots, b_1, 0)$.
- ◊ Set $V^\uparrow := (v_{k+1-i,j}) \in \text{Mat}(\mathbf{a}^*, \mathbf{b})$ and $V'^\uparrow := (v_{j,k+1-i}) \in \text{Mat}(\mathbf{b}^*, \mathbf{a})$.
- ◊ Let $Y \in \text{YT}(\pi/\sigma, \mathbf{b})$ be the tableau with recording matrix V^\uparrow .
 - ◊ Compute $B = \psi(Y)$.
- ◊ Let $X \in \text{YT}(\rho/\tau, \mathbf{a})$ be the tableau with recording matrix V'^\uparrow .
 - ◊ Compute $A = \psi(X)$.
- ◊ Output $(B, A) = \varphi(V)$.

The above circuit is a simple parallel circuit which uses ψ twice. To prove that it computes φ , apply Proposition 3.

4.4 Reduction $\psi \hookrightarrow \phi$

The linear reduction of the Jeu de Taquin map ψ to the Littlewood-Robinson map ϕ follows immediately from Proposition 5. The corresponding circuit is a trivial circuit $I(\text{id}, \phi, \delta)$, where id is the identity map, and δ is a projection onto the first component.

4.5 Reduction $\phi \hookrightarrow \zeta^N$

The linear reduction of the Littlewood-Robinson map ϕ to the Tableau Switching map for normal shapes ζ^N follows from the definition of ϕ given before Proposition 11. Below we present the corresponding ζ^N -based ps-circuit proving $\phi \hookrightarrow \zeta^N$.

- ◇ Input k, \mathbf{a} , partitions λ, μ , such that $\ell(\mathbf{a}), \ell(\lambda) \leq k$.
- ◇ Input $A \in \text{YT}(\lambda/\mu, \mathbf{a})$.
- ◇ Set $B = \text{Can}(\mu)$.
 - ◇ Compute $(A', B') = \zeta^N(B, A)$.
- ◇ Let σ be the shape of A' .
- ◇ Set $C = \text{Can}(\sigma)$.
 - ◇ Compute $(B'', C') = \zeta^N(C, B')$.
- ◇ Output $(A', C') \in \text{YT}(\sigma, \mathbf{a}) \times \text{LR}(\lambda/\mu, \sigma)$.

The above circuit is a simple sequential circuit which uses map ζ^N twice. Its correctness follows immediately from our definition of ϕ .

4.6 Reductions $\zeta \hookrightarrow \xi$ and $\zeta^N \hookrightarrow \xi^N$

The linear reduction of the Tableau Switching map ζ to the Schützenberger involution ξ is given by the following simple sequential circuit.

- ◇ Input $k, \mu \subset \pi \subset \lambda, \mathbf{a}, \mathbf{b}$, such that $\ell(\lambda), \ell(\mathbf{a}), \ell(\mathbf{b}) \leq k$.
- ◇ Input $A \in \text{YT}(\lambda/\pi, \mathbf{a}), B \in \text{YT}(\pi/\mu, \mathbf{b})$.
 - ◇ Compute $B' = \xi(B) \in \text{YT}(\pi/\mu, \mathbf{b}^*)$, where $\mathbf{b}^* = (b_k, \dots, b_1)$.
- ◇ Relabel integers in A by adding k to them.
- ◇ Let $C := B' \star A \in \text{YT}(\lambda/\mu, (b_k, \dots, b_1, a_1, \dots, a_k))$.
 - ◇ Compute $C' = \xi(C) \in \text{YT}(\lambda/\mu, (a_k, \dots, a_1, \underline{b}_1, \dots, b_k))$.
- ◇ Decompose $C' := A' \star B''$, where $B'' \in \text{YT}(\lambda/\sigma, \mathbf{b}), A' \in \text{YT}(\sigma/\mu, \mathbf{a}^*)$, $\tilde{\mathbf{b}} = (0, \dots, 0, b_1, \dots, b_k)$, with k zeros, and $\sigma \vdash |\mu| + |\mathbf{a}|$.
- ◇ Relabel integers in B'' by subtracting k from them.
 - ◇ Compute $A'' = \xi(A') \in \text{YT}(\sigma/\mu, \mathbf{a})$.
- ◇ Output $(A'', B'') = \zeta(B, A)$.

This gives a sequential circuit which uses ξ three times. We illustrate it in Figure 9. Here we use $\tilde{\mathbf{a}} = (0, \dots, 0, a_1, \dots, a_k)$, with k zeros and keep notation A, B'' for tableaux before and after relabelling. We hope this won't lead to the confusion.

Lemma 1. *The above ξ -based circuit computes ζ .*

We postpone the proof till Section 5.3.1. The proof is based on Propositions 1 and 2 in Section 3.1. When μ is the empty partition the above becomes a ξ^N -based circuit that computes ζ^N .

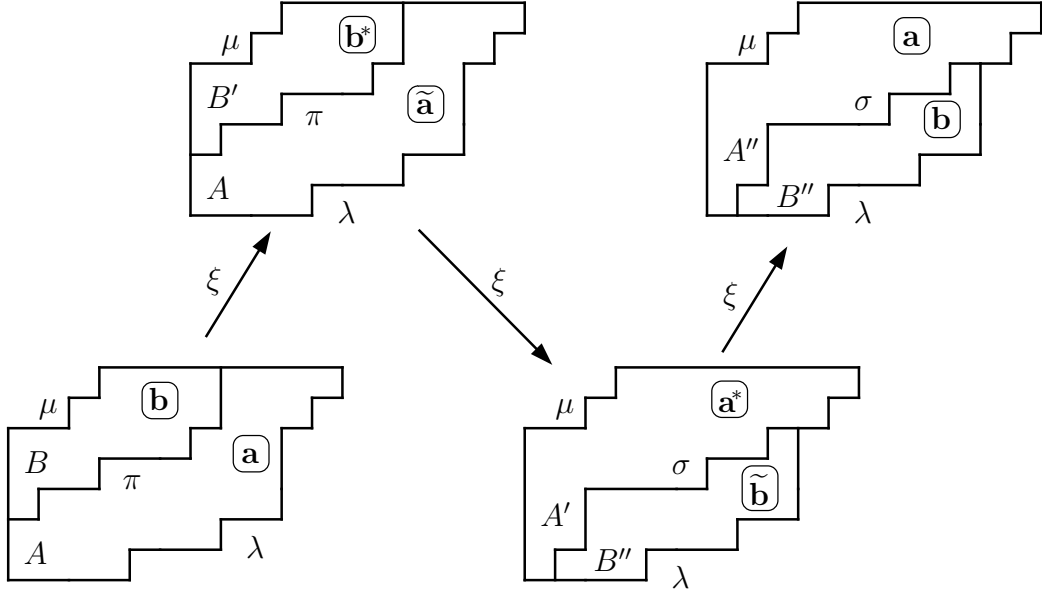

Figure 9: Illustration of the linear reduction $\zeta \leftrightarrow \xi$.

4.7 Reduction $\xi^N \leftrightarrow \varphi$

The linear reduction of the Schützenberger involution for normal shapes ξ^N to the RSK correspondence φ is given by the following simple sequential circuit. The construction is based on Proposition 8.

- ◇ Input k, λ, \mathbf{a} , such that $\ell(\lambda), \ell(\mathbf{a}) \leq k$.
- ◇ Input $A \in \text{YT}(\lambda, \mathbf{a})$.
- ◇ Set $V = (v_{i,j})$ be the recording matrix of A . Let $U = (u_{i,j}) := (v_{i,k-j+1})$.
 - ◇ Compute $(A^\circ, B^\circ) = \varphi(U)$.
- ◇ Output $A^\circ = \xi^N(A) \in \text{YT}(\lambda, \mathbf{a}^*)$.

The above is a trivial circuit which uses map φ only once.

Lemma 2. *The above φ -based circuit computes ξ^N .*

The proof of the lemma follows from Proposition 8 and additional considerations, which will be given in Section 5.3.2.

4.8 Reductions $\rho_1 \leftrightarrow \zeta^N \leftrightarrow \zeta$

The linear reduction of the First Fundamental Symmetry map ρ_1 to the Tableau Switching map for normal shapes ζ^N follows immediately from Proposition 10. The corre-

sponding circuit is a trivial circuit $I(\delta_1, \zeta, \delta_2)$ where δ_1 creates a canonical tableau $B = \text{Can}(\mu)$, $\zeta : (B, A) \mapsto (A', B')$, and δ_2 is a projection on the second component B' . We leave the easy technical details to the reader. The linear reduction $\zeta^{\text{N}} \hookrightarrow \zeta$ is trivial.

4.9 Reduction $\zeta \hookrightarrow \rho_1$

This reduction is more involved than other linear reductions, and requires an intermediate map ζ^{LR} . Formally, we first present a linear reduction $\zeta \hookrightarrow \zeta^{\text{LR}}$, and then a linear reduction $\zeta^{\text{LR}} \hookrightarrow \rho_1$. Now the Composition Lemma gives the desired construction.

4.9.1 Reduction $\zeta \hookrightarrow \zeta^{\text{LR}}$

Suppose $\mu \subset \lambda$, $n = |\lambda/\mu|$, and $|\nu| + |\tau| = n$. Define *LR-Tableau Switching* to be a one-to-one correspondence:

$$\zeta^{\text{LR}} : \bigcup_{\pi \vdash |\lambda| - |\nu|} \text{LR}(\pi/\mu, \tau) \times \text{LR}(\lambda/\pi, \nu) \longrightarrow \bigcup_{\sigma \vdash |\lambda| - |\tau|} \text{LR}(\sigma/\mu, \nu) \times \text{LR}(\lambda/\sigma, \tau),$$

which is given by restriction of ζ to the sets as above.

Proposition 16. *The map ζ^{LR} is a well defined bijection.*

The reduction $\zeta^{\text{LR}} \hookrightarrow \zeta$ is trivial, but will not be needed. Below we show that $\zeta \hookrightarrow \zeta^{\text{LR}}$, which implies that $\zeta^{\text{LR}} \sim \zeta$.

We first describe the working of the reduction. Start with tableaux A, B and consider a tableau $(B \star A) \circ C \circ D$, where C contains only integers as in A and D contains only integers as in B (see Figure 10). Let $\widehat{A} := A \circ_{s,0} C$, $\widehat{B} := B \circ_{t,k} D$ be parts of the tableau above, for some s, t, k to be defined; recall the definition of $\circ_{a,b}$ in Section 1. Clearly, tableau switching of \widehat{A} and \widehat{B} gives $B' \circ_{t,k} D$, $A' \circ_{s,0} C$, where $(A', B') = \zeta(B, A)$. Now, if $A \circ_{s,0} C$ and $B \circ_{t,k} D$ are LR-tableaux, this gives a linear reduction as desired. Below we show that one always find tableaux C, D as above.

- ◇ Input $k, \mu \subset \pi \subset \lambda, \mathbf{c}, \mathbf{d}$, such that $\ell(\lambda), \ell(\mathbf{c}), \ell(\mathbf{d}) \leq k$.
- ◇ Input $A \in \text{YT}(\lambda/\pi, \mathbf{c}), B \in \text{YT}(\pi/\mu, \mathbf{d})$.
- ◇ Set $\alpha := (c_2 + \cdots + c_k, c_3 + \cdots + c_k, \dots, c_k, 0)$.
- ◇ Set $\beta := (d_2 + \cdots + d_k, d_3 + \cdots + d_k, \dots, d_k, 0)$.
- ◇ Set $\widehat{\lambda} := (\lambda_1 + \alpha_1 + \beta_1, \dots, \lambda_1 + \alpha_1 + \beta_k, \lambda_1 + \alpha_1, \dots, \lambda_1 + \alpha_k, \lambda_1, \dots, \lambda_k)$.
- ◇ Set $\widehat{\pi} := (\lambda_1 + \alpha_1 + \beta_1, \dots, \lambda_1 + \alpha_1 + \beta_k, \lambda_1, \dots, \lambda_1, \pi_1, \dots, \pi_k)$.
- ◇ Set $\widehat{\mu} := (\lambda_1 + \alpha_1, \dots, \lambda_1 + \alpha_1, \lambda_1, \dots, \lambda_1, \mu_1, \dots, \mu_k)$.
- ◇ Set $\widehat{A} := A \circ_{\lambda_1,0} \text{Can}(\alpha) \in \text{LR}(\widehat{\lambda}/\widehat{\pi}), \widehat{B} := B \circ_{\lambda_1+\alpha_1,k} \text{Can}(\beta) \in \text{LR}(\widehat{\pi}/\widehat{\mu})$.
 - ◇ Compute $(\widehat{A}', \widehat{B}') = \zeta^{\text{LR}}(\widehat{B}, \widehat{A})$.
- ◇ Decompose $\widehat{A}' = A' \circ_{\lambda_1,0} \text{Can}(\alpha), \widehat{B}' = B' \circ_{\lambda_1+\alpha_1,k} \text{Can}(\beta)$, where

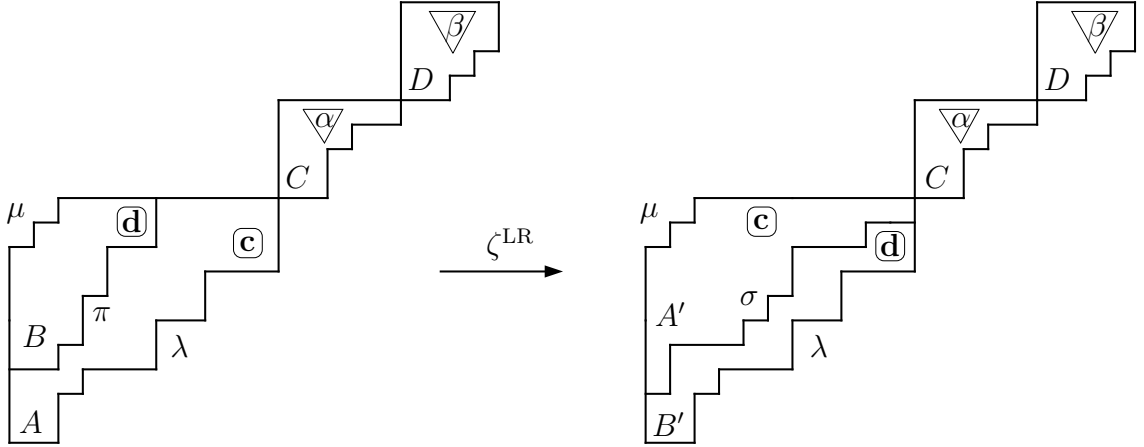

Figure 10: Illustration of the linear reduction $\zeta \leftrightarrow \zeta^{\text{LR}}$.

$A' \in \text{YT}(\sigma/\mu, \mathbf{c})$, $B' \in \text{YT}(\lambda/\sigma, \mathbf{d})$, for some $\sigma \vdash |\lambda/\pi|$.

◇ Output $(A', B') = \zeta(B, A)$.

Lemma 3. *The above ζ^{LR} -based trivial circuit computes ζ .*

Its correctness follows from Proposition 16 and the fact that the Tableaux Switching map commutes with taking compositions [6, Thm. 2.3]. We postpone the proof till Section 5.3.3.

4.9.2 Reduction $\zeta^{\text{LR}} \leftrightarrow \rho_1$

First, we describe the working of the reduction. Start with tableaux $A \in \text{LR}(\lambda/\pi, \nu)$, $B \in \text{LR}(\pi/\mu, \tau)$. We need to obtain $(A', B') = \zeta(B, A)$. Think of ρ_1 as tableau switching with a canonical tableau. Computing $\rho_1(B)$ is a tableau switching of $\text{Can}(\mu)$ and B . Similarly, computing $\rho_1(\rho_1(B) \star A)$ is a tableau switching which first returns to B and then switches B and A (see Figure 11). This step works only if $\rho_1(B) \star A$ is a LR-tableau. Thus, we extend $\rho_1(B) \star A$ to a tableau E that is a LR-tableau, and apply ρ_1 to E instead of applying it to $\rho_1(B) \star A$. Finally, we apply ρ_1 to restriction of tableau $\rho_1(E)$ to integers $1, \dots, k$ (see Figure 12).

- ◇ Input $k, \mu \subset \pi \subset \lambda, \nu, \tau$, such that $\ell(\lambda), \ell(\nu), \ell(\tau) \leq k$.
- ◇ Input $A \in \text{LR}(\lambda/\pi, \nu)$, $B \in \text{LR}(\pi/\mu, \tau)$.
 - ◇ Compute $C := \rho_1(B) \in \text{LR}(\pi/\tau, \mu)$.
- ◇ Set $s := \nu_1, t := \lambda_1$.
- ◇ Set $\gamma := (s^k)$, $G := \text{Can}(\gamma)$.
- ◇ Set $\hat{\pi} := (t + s, \dots, t + s, \pi_1, \dots, \pi_k)$, $\hat{\lambda} := (t + s, \dots, t + s, \lambda_1, \dots, \lambda_k)$,

- $\widehat{\tau} := (t, \dots, t, \tau_1, \dots, \tau_k)$, all of length $2k$.
- ◇ Set $\widetilde{\mu} := (s + \mu_1, \dots, s + \mu_k)$, $\varkappa := (s + \mu_1, \dots, s + \mu_k, \nu_1, \dots, \nu_k)$.
 - ◇ Relabel the integers in A by adding k to them.
 - ◇ Set $\widehat{C} := C \circ_{\lambda_1, 0} G \in \text{LR}(\widehat{\pi}/\widehat{\tau}, \widetilde{\mu})$, $D := \widehat{C} \star A \in \text{LR}(\widehat{\lambda}/\widehat{\tau}, \varkappa)$.
 - ◇ Compute $E := \rho_1(D) \in \text{LR}(\widehat{\lambda}/\varkappa, \widehat{\tau})$.
 - ◇ Set $\delta := (t, \dots, t)$ of length k , and $\widetilde{\tau} = (0, \dots, 0, \tau_1, \dots, \tau_k)$ of length $2k$.
 - ◇ Decompose $E = F \star B'$, where $F \in \text{LR}(\widehat{\sigma}/\varkappa, \delta)$, $B' \in \text{YT}(\lambda/\sigma, \widetilde{\tau})$, $\widehat{\sigma} = (t + s, \dots, t + s, \sigma_1, \dots, \sigma_k)$ of length $2k$, for some $\sigma \vdash |\lambda/\tau|$.
 - ◇ Relabel the integers in B' by subtracting k from them: now $B' \in \text{LR}(\lambda/\sigma, \tau)$.
 - ◇ Compute $H := \rho_1(F) \in \text{LR}(\widehat{\sigma}/\delta, \varkappa)$.
 - ◇ Set $\widetilde{\nu} = (0, \dots, 0, \nu_1, \dots, \nu_k)$ of length $2k$.
 - ◇ Decompose $H = (\text{Can}(\mu) \circ_{\lambda_1, 0} G) \star A'$, where $A' \in \text{YT}(\sigma/\mu, \widetilde{\nu})$.
 - ◇ Relabel the integers in A' by subtracting k from them: now $A' \in \text{LR}(\sigma/\mu, \nu)$.
 - ◇ Output $(A', B') \in \text{LR}(\sigma/\mu, \nu) \times \text{LR}(\lambda/\sigma, \tau)$.

The above circuit is a sequential circuit which uses map ρ_1 three times. Its correctness is summarized in the following lemma.

Lemma 4. *The above ρ_1 -based sequential circuit computes the restricted tableau switching map ζ^{LR} .*

We prove the lemma in Section 5.3.4.

4.9.3 Using duality

One can use the duality (rotating the picture 180 degree and relabelling the integers) and apply ρ_1 twice as in the beginning of the circuit above (in place of the the third application of ρ_1). This gives a conceptually easier ρ_1 -based ps-circuit for ζ^{LR} , but with a higher cost.

4.9.4 Reduction $\zeta \leftrightarrow \zeta^{\text{N}}$

Note that it is not difficult to define directly a linear reduction $\zeta \leftrightarrow \zeta^{\text{N}}$. Even though we do not need this reduction, let us quickly outline it.

Let $B \in \text{YT}(\pi/\mu, \mathbf{d})$, $A \in \text{YT}(\lambda/\pi, \mathbf{c})$ and $C = \text{Can}(\mu)$. Relabel the entries of B by adding k to them, and compute $(A', D') = \zeta^{\text{N}}(C \star B, A)$. Decompose $D' = C' \star B'$, where C' has content μ . Let σ be the shape of D' . Relabel the entries of B' by subtracting k from them; thus $B' \in \text{YT}(\lambda/\sigma, \mathbf{d})$. Let $(C'', A'') = \zeta^{\text{N}}(A', C')$. Since $C'' = \text{Can}(\mu)$, we have that $A'' \in \text{YT}(\sigma/\mu, \mathbf{c})$. We leave as an exercise to the interested reader to show that $(A'', B') = \zeta(B, A)$. In this way we obtain a sequential ζ^{N} -based circuit which computes ζ .

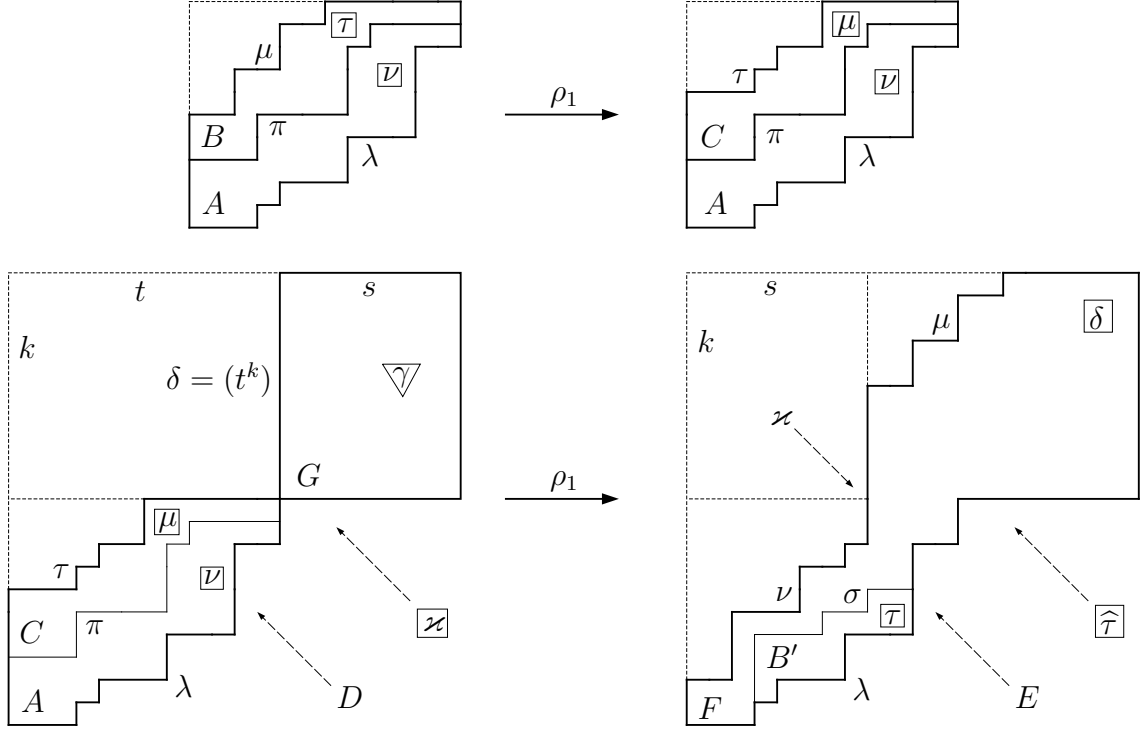

Figure 11: Illustration of the first two applications of ρ_1 in linear reduction $\zeta^{\text{LR}} \hookrightarrow \rho_1$.

4.10 Reduction $\rho_2 \hookrightarrow \xi^{\text{N}}$

The linear reduction of the Second Fundamental Symmetry map ρ_2 to Schützenberger involution map ξ follows immediately from the definition of ρ_2 and Proposition 14. The corresponding circuit is a trivial circuit $I(\gamma, \xi, \tau^{-1})$.

4.11 Reduction $\xi^{\text{N}} \hookrightarrow \rho_2$

We describe first the working of the reduction. Let $A \in \text{YT}(\mu, \mathbf{a})$, with $\mathbf{a} = (a_1, \dots, a_k)$. Define $\nu = (a_1 + \dots + a_{k-1}, a_1 + \dots + a_{k-2}, \dots, a_1, 0)$ and $\lambda = \nu + \mathbf{a}^*$. Then $A^{\bullet} \circ \text{Can}(\nu) \in \text{LR}(\mu^{\bullet} \circ \nu, \lambda)$ and $A \in \text{CF}^*(\mu, \nu, \lambda)$. Let $A^{\circ} = \tau \circ \rho_2 \circ \gamma^{-1}(A) \in \text{CF}(\mu, \nu, \lambda)$. By the definition of ρ_2 we have $A^{\circ} = \xi^{\text{N}}(A)$. Therefore, we have proved that the following trivial circuit $I(\gamma^{-1}, \rho_2, \tau)$ computes ξ^{N} .

- ◇ Input k, \mathbf{a}, μ , such that $\ell(\mu), \ell(\mathbf{a}) \leq k$.
- ◇ Input $A \in \text{YT}(\mu, \mathbf{a})$.
- ◇ Set $\nu := (a_1 + \dots + a_{k-1}, a_1 + \dots + a_{k-2}, \dots, a_1, 0)$, $\lambda := \nu + \mathbf{a}^*$.
- ◇ Set $B := \gamma^{-1}(A)$.

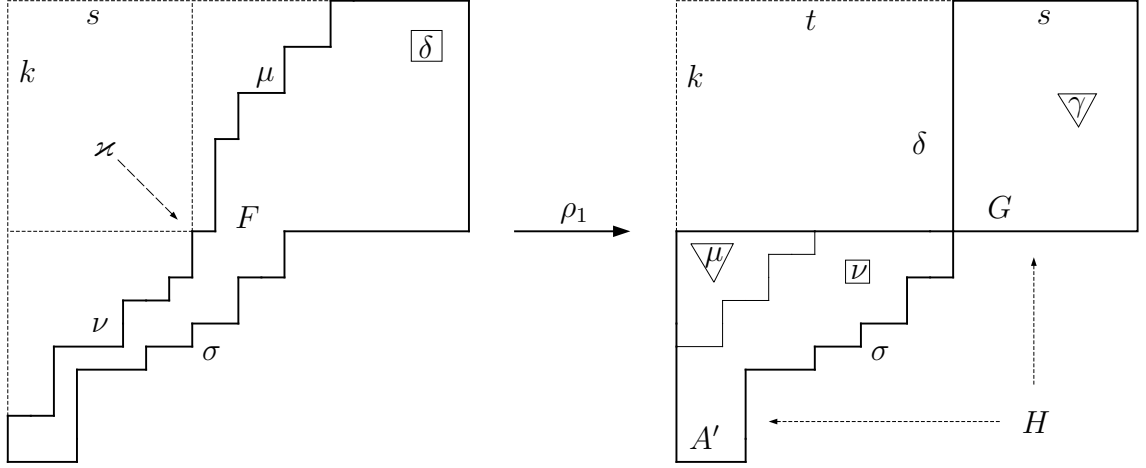

Figure 12: Illustration of the of the third application of ρ_1 in linear reduction $\zeta^{\text{LR}} \hookrightarrow \rho_1$.

- ◇ Compute $C := \rho_2(B)$.
- ◇ Set $A^\circ := \tau(C)$.
- ◇ Output $A^\circ = \xi^N(A) \in \text{YT}(\mu, \mathbf{a}^*)$.

4.12 Reduction $\xi^N \hookrightarrow \chi$

The reduction $\xi^N \hookrightarrow \chi$ is trivial, since when $\mu = \emptyset$, χ coincides with ξ^N .

4.13 Reduction $\chi \hookrightarrow \xi^N$

The linear reduction of the reversal map to the Schützenberger involution for normal shapes is given by the following circuit.

- ◇ Input $k, \mu \subset \lambda, \mathbf{a}$, such that $\ell(\lambda), \ell(\mathbf{a}) \leq k$.
- ◇ Input $A \in \text{YT}(\lambda/\mu, \mathbf{a})$.
- ◇ Set $C := \text{Can}(\mu)$.
 - ◇ Compute $C^\circ := \xi^N(C) \in \text{YT}(\mu, \mu^*)$.
- ◇ Set $\mathbf{c} := (\mu_k, \dots, \mu_1, a_1, \dots, a_k)$, $\mathbf{d} := (a_1, \dots, a_k, \mu_1, \dots, \mu_k)$ of length $2k$.
- ◇ Set $\tilde{\mu} := (0, \dots, 0, \mu_1, \dots, \mu_k)$ of length $2k$.
- ◇ Relabel de entries of A by adding k to them.
- ◇ Let $B := C^\circ \star A \in \text{YT}(\lambda, \mathbf{c})$.
 - ◇ Compute $B^\circ := \xi^N(B) \in \text{YT}(\lambda, \mathbf{c}^*)$
- ◇ Decompose $B^\circ = A^\circ \star C'$, where $A^\circ \in \text{YT}(\nu, \mathbf{a}^*)$, $C' \in \text{YT}(\lambda/\nu, \tilde{\mu})$ for some partition $\nu \vdash |\mathbf{a}|$.

- ◇ Compute $A^{\circ\circ} := \xi^N(A^\circ) \in \text{YT}(\nu, \mathbf{a})$.
- ◇ Let $B^{\circ\circ} := A^{\circ\circ} \star C' \in \text{YT}(\lambda, \mathbf{d})$.
 - ◇ Compute $B^\nabla := \xi^N(B^{\circ\circ}) \in \text{YT}(\lambda, \mathbf{d}^*)$.
- ◇ Decompose $B^\nabla := C^\circ \star A^\nabla$.
- ◇ Relabel the entries of A^∇ by subtracting k from them.
- ◇ Output $\chi(A) := A^\nabla \in \text{YT}(\lambda/\mu, \mathbf{a}^*)$.

The above circuit is a simple sequential circuit which uses the map ξ^N four times (see Figure 13).

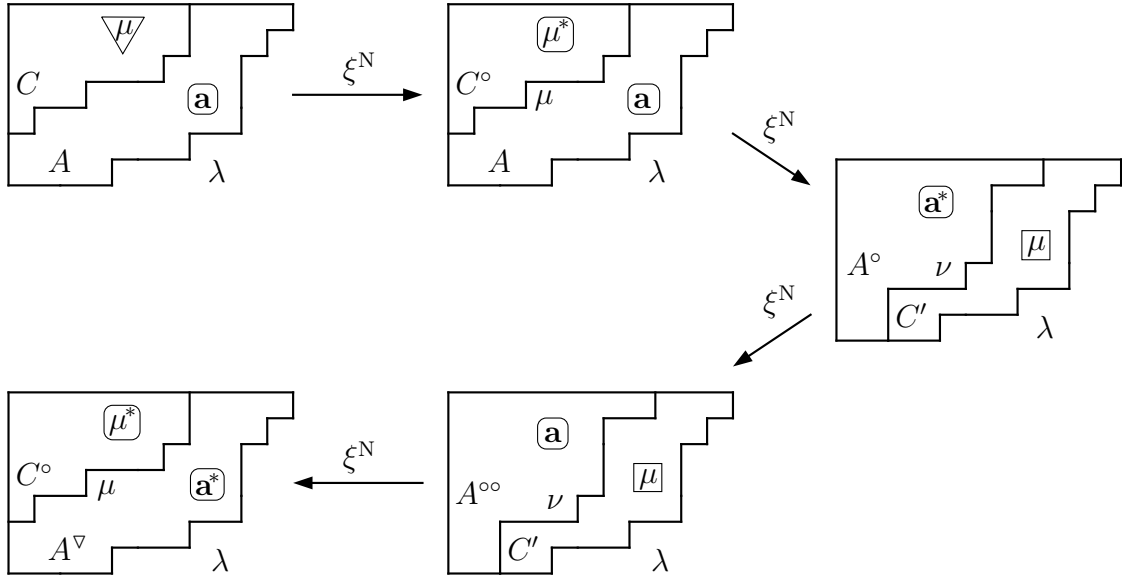

Figure 13: Illustration of the reduction $\chi \leftrightarrow \xi^N$.

Lemma 5. *The above ξ^N -based circuit computes χ .*

In fact, since $C^\circ = \xi^N(\text{Can}(\mu))$ can be given explicitly, we could write the circuit using the map ξ^N only three times. Formally, to prove this we need the following result:

Lemma 6. *Map $\mu \rightarrow \xi^N(\text{Can}(\mu))$ can be computed in $O(k^2)$ time, where $k = \ell(\mu)$.*

We prove both lemmas in Section 5.3.

4.14 Proof of Main Lemma

Main Lemma (Section 4.1) now follows immediately from reductions above (sections 4.3 to 4.13).

5 Proof of results

As we mentioned in the Introduction, there is an extensive literature in the subject of Young tableau bijections. Thus in many cases the technical results we need are already known. In the next subsection we give a brief overview the literature giving pointers to propositions. Readers interested in a modern treatment of the subject, complete definitions and further references, are referred to [12, 36, 43]. An historic overview of several of the constructions used here can be found in [26, 27]. The remainder of this section contains proofs of lemmas and theorems.

5.1 Brief overview of the literature

The Schützenberger involution or evacuation and the Jeu de Taquin were introduced by M.-P. Schützenberger in his study of the combinatorics of Young tableaux [38, 40]. The Schützenberger involution is usually considered only in the case $\mu = \emptyset$, but in fact Schützenberger extended this map to every poset [39]. Proposition 6 follows from Proposition 3 and the duality theorem in Appendix A1 in [12] or from Theorem A1.2.10 in [43]. For Proposition 9 see [12, §5.2] or [43, A1.3.6]. An alternative extension of the Schützenberger involution to skew shapes is the reversal map considered by Benkart, Sottile and Stroomer in [6, §5]. The reversal of a skew tableau can be characterized by means of *dual equivalence* [16], although this is not the case for Schützenberger involution in the case of skew shapes. Proposition 15 is proved in §5 of [6] and follows from the fact that it is defined as the composition of three bijections and relations (\boxtimes).

Bender-Knuth transformations were introduced by E. Bender and D.E. Knuth in their work on the enumeration of plane partitions [5]. Their connection with Schützenberger involution was realized much later. Proposition 1 is explicit in [22, §2C], although it was probably discovered much earlier.

The RSK correspondence in full generality is due to Knuth [23], who built it based on previous works of Robinson [35] and Schensted [37] (and conversations with Schützenberger). Proposition 3 can be found in [40] or [45, §4] and Proposition 7 in [23]. Proposition 8 appears in [24, Thm. D], [43, App. A] for standard tableaux, and in [12, App. A1] for tableaux of arbitrary weight.

Tableau switching, defined by means of the Bender-Knuth transformations, was used by James and Kerber [21, §2.8] in a proof of the LR-rule. More recently, the tableau switching map was defined in a more general context in [6]; there its main properties were established. This is what we call the Tableau Switching map. See also [27, §2] for applications of tableau switching. Proposition 2 is Proposition 2.6 in [6], Proposition 4 is contained in [6, §2], and Proposition 16 is a part of Theorem 3.1 in [6].

The Littlewood-Robinson map (and other bijections of this type) remains little studied despite being one of the oldest Young tableau bijections. The first such map was defined by Robinson [35] in a different language in his effort to prove the LR-rule.

His proof was reworked by Macdonald in the first edition of [28, I9]. For a detailed account on Robinson's paper see [27]; in Section 2.5 of this paper, van Leeuwen defines another bijection of Littlewood-Robinson type using the Tableau Switching map. This bijection, given here in Section 3.3, is the one we call the Littlewood-Robinson map. In fact, van Leeuwen proves in [27] that this map coincides with the original one defined by Robinson and reworked by Macdonald. From the point of view of the LR-rule this is unimportant, since any such bijection yields a proof of the LR-rule. Moreover, van Leeuwen shows using his definition that the Littlewood-Robinson map enjoys nice properties, such as Proposition 5 in this paper and Corollary 2.5.2 in [27]. Proposition 5 follows from Proposition 4, and Proposition 11 follows from Proposition 2 and the relations (\boxtimes) .

The problem of finding what we call a Fundamental Symmetry map appears to be part of the 'folklore' of the area; it is very natural and has been considered independently by several investigators (see e.g. [2, 3, 7, 19]). Proposition 10 regarding our first map ρ_1 is contained in [6, Example 3.6]. The Fundamental Symmetry maps ρ_2 and ρ_2' are new to our best knowledge. They are a byproduct of [32], and were motivated by Fulton's appendix to [8]. More precisely, $\gamma(A)^\bullet$ is the composition of the linear map Φ_l , between LR-triangles and hives, defined in [32, §4], with Fulton's map in [8], or equivalently the composition of the linear map $\Psi_{l+1} \circ \Phi_{l+1}$, between LR-triangles with last row equal to zero and Berenstein-Zelevinsky triangles, defined in [32, §5], with Carré's map in [11, §3]. Thus, Proposition 12 follows from [32] and Fulton [12] (which itself is based on Carré's work [11]). Note that both Carré and Fulton's papers use set of tableaux $CF^*(\lambda, \mu, \nu)$ to give combinatorial interpretations of LR-coefficients $c_{\mu, \nu}^\lambda$, which they connect to BZ-triangles and hives, respectively. In fact, the linear map γ gives a simple combinatorial proof of $c_{\mu, \nu}^\lambda = |CF^*(\lambda, \mu, \nu)|$; in this form it is new to the best of our knowledge (cf. [32]).

The tableau $\tau(A)$ is called the companion tableau of A in [27, §1.4]. Proposition 13 is equivalent to Proposition 1.4.3 there; its proof is straightforward. Proposition 14 follows from Propositions 6, 12 and 13.

It is perhaps interesting to observe that the map $\Psi_l \circ \Phi_l$ from LR-triangles to BZ-triangles, given in [32, §5], essentially contains γ and τ . More precisely, let A be a LR-tableau with LR-triangle $(a_{i,j})$, and let $\Psi_l \circ \Phi_l(a_{i,j}) = (x_{i,j}, y_{i,j}, z_{i,j})$. Note that the recording matrix $C = (c_{i,j})$ of A satisfies $c_{i,j} = a_{j,i}$. Suppose $\gamma(A) = (d_{i,j})$ and $\tau(A) = (e_{i,j})$, then $d_{i,j} = x_{l-j+1, l-j+i}$ and $e_{i,j} = y_{i,j-1}$ for all $i < j$. Besides, the numbers $d_{i,i}$ can be recovered from the $d_{i,j}$'s and the μ_j 's, and the numbers $e_{i,i}$ can be recovered from the $e_{i,j}$'s and the ν_j 's. It should be noted that while ρ_1 is an *involution*, we do not know whether ρ_2 and ρ_2' are, or equivalently, if $\rho_2 = \rho_2'$; but, see Conjecture 1 in Section 6.1.

5.2 Proof of relation (\otimes)

Since, by relation (\boxtimes) one has that $t_{l,k} = t_{k,l}^{-1}$, it is enough to prove that

$$z_k t_{k,l}^{-1} z_l = z_{k+l}.$$

This identity follows easily from the relations (\diamond) of the BK-transformations:

$$\begin{aligned} z_k t_{k,l}^{-1} z_l &= [(s_1)(s_2 s_1) \cdots (s_{k-1} s_{k-2} \cdots s_2 s_1)] \cdot [(s_k s_{k-1} \cdots s_2 s_1)(s_{k+1} s_k \cdots s_3 s_2) \\ &\quad (s_{k+2} s_{k+1} \cdots s_4 s_3) \cdots (s_{k+l-1} s_{k+l-2} \cdots s_{\ell+1} s_\ell)] \cdot [(s_1)(s_2 s_1) \cdots (s_{\ell-1} s_{\ell-2} \cdots s_2 s_1)] \\ &= [(s_1)(s_2 s_1) \cdots (s_{k-1} s_{k-2} \cdots s_2 s_1)] \cdot [(s_k s_{k-1} \cdots s_2 s_1)(s_{k+1} s_k \cdots s_3 s_2)(s_1) \\ &\quad (s_{k+2} s_{k+1} \cdots s_4 s_3)(s_2 s_1) \cdots (s_{k+l-1} s_{k+l-2} \cdots s_{\ell+1} s_\ell)(s_{\ell-1} s_{\ell-2} \cdots s_2 s_1)] \\ &= (s_1)(s_2 s_1) \cdots (s_k s_{k-1} \cdots s_2 s_1) \cdots (s_{k+l-1} s_{k+l-2} \cdots s_2 s_1) = z_{k+l}. \end{aligned}$$

Here the second equality follows from commuting parenthesized products in z_l with the the previous products in $t_{k,l}^{-1}$.

5.3 Proof of lemmas

5.3.1 Proof of Lemma 1

Let $k = \ell(B)$ and $l = \ell(A)$. Use Propositions 1 and 2 to write Schützenberger involution and Tableau Switching up to relabelling as products of BK-transformations. In the notation of Section 3.1, we need to prove that

$$t_{k,l} = z_l z_{k+l} z_k.$$

This follows from relations (\boxtimes) and (\otimes) .

5.3.2 Proof of Lemma 2

Let $A \in \text{YT}(\lambda, \mathbf{a})$ with recording matrix $V = (v_{i,j})$. Then, by Proposition 3 for $V^\uparrow = (v_{k+1-i,j})$, we have $\varphi(V^\uparrow) = (A, -)$. Since $V^{\uparrow*} = (v_{i,k+1-j}) = U$, Proposition 8 implies $\varphi(U) = (\xi^N(A), -)$, and the claim follows.

5.3.3 Proof of Lemma 3

First, we need to show that \widehat{A} and \widehat{B} are both LR-tableaux. Indeed, since C is canonical, the integer (i) appears α_i times in C , which is the total number of times $(i+1)$ appears in A . Therefore, when reading the **word**(\widehat{A}), the number of integers (i) is always at least as many as the number of integers $(i+1)$. By definition, this implies that \widehat{A} is a LR-tableau, and the same argument works for \widehat{B} .

Now observe that tableaux C and D remain unchanged under ζ . Furthermore, since ζ^{LR} is applicable and well defined, we easily see that action of ζ^{LR} restricted to (B, A) coincides with the action of ζ on (B, A) . Indeed, simply observe that BK-transformations commute with taking compositions of tableaux. Thus, so do elements $t_{r, m-r}$ and by Proposition 2, the Tableau Switching map ζ . Therefore, the restriction of ζ^{LR} to (B, A) coincides with ζ , which implies the result.

5.3.4 Proof of Lemma 4

We need the following property of tableau switching given in [6, Thm. 2.3]. Let $(X, Y) = \zeta(U, V \star W)$; then, there is an alternative way to calculate (X, Y) . Start with $(V', U') = \zeta(U, V)$, and compute $(W', U'') = \zeta(U', W)$. Then $(X, Y) = (V' \star W', U'')$. By the symmetry (\boxtimes), the same “distributivity” property holds for $(X', Y') = \zeta(U \star V, W)$. During the proof we will adopt the following convention: if U and V are tableaux filled with integers $1, \dots, k$ then by $U \star V$ we will denote the tableau obtained by relabelling the entries of V by adding k to them, and then taking the union of U and V (if this is possible).

Let $(\overline{A}, \overline{B}) = \zeta(B, A)$, and let A', B' be defined as in reduction 4.9.2. We have to show that $\overline{A} = A'$ and $\overline{B} = B'$. Now, by Proposition 10, the map ρ_1 is a special case of the Tableau Switching map ζ . The first application of ζ computes $(\text{Can}(\tau), C) = \zeta(\text{Can}(\mu), B)$. The second application of ζ computes $(\text{Can}(\varkappa), \widehat{B}')$ as the switching of $(\text{Can}(\widehat{\tau}), (C \circ_{\lambda_1, 0} G) \star A)$. By decomposing $\text{Can}(\widehat{\tau})$ as $\text{Can}(\delta) \star \text{Can}(\tau)$, and $\text{Can}(\varkappa)$ as $\text{Can}(\widetilde{\mu}) \star \text{Can}(\nu)$ we obtain

$$(\diamond) \quad (\text{Can}(\widetilde{\mu}) \star \text{Can}(\nu), F \star B') = \zeta(\text{Can}(\delta) \star \text{Can}(\tau), (C \circ_{\lambda_1, 0} G) \star A).$$

Recall that tableau switching commutes with taking compositions (see Subsection 5.3.3 above), and observe that $\text{Can}(\tau)$ lies to the left and below G . Now, by the “distributivity” property, the second application of ζ starts with tableau switching of $\text{Can}(\tau)$ and C , which is the inverse of the first application of ζ . The resulting tableau B is then switched with A , giving B' as desired. The remaining steps to be done according to the “distributivity” property as above do not change the tableaux B' as it contains the largest integers $k + 1, \dots, 2k$. Therefore, $\overline{B} = B'$. The third application of ζ switches F with $\text{Can}(\widetilde{\mu}) \star \text{Can}(\nu)$, but according to (\diamond), $\text{Can}(\tau)$ switches first with $(C \circ_{\lambda_1, 0} G) \star A$ yielding $(\text{Can}(\mu) \circ_{\lambda_1, 0} G) \star \overline{A}, \overline{B}$; then $\text{Can}(\delta)$ switches with $(\text{Can}(\mu) \circ_{\lambda_1, 0} G) \star \overline{A}$ yielding $(\text{Can}(\widetilde{\mu}) \star \text{Can}(\nu), F)$. Therefore $\rho_1(F) = (\text{Can}(\mu) \circ_{\lambda_1, 0} G) \star \overline{A}$, and restricting this tableau to the last k integers gives $\overline{A} = A'$, as desired.

It remains to show that ρ_1 is applicable the three times in the circuit. Since B is already LR-tableau, the first application is valid. By Proposition 10, the resulting tableau C is also LR. We need to show that $(C \circ_{\lambda_1, 0} G) \star A$ is LR-tableau. Since $(C \circ_{\lambda_1, 0} G)$ and A are already LR-tableau, all we need to show is that the number of $(k + 1)$'s is

always at most the number of k 's in a word. But that is clear since there are $s = \nu_1$ integers k in G , which all appear before the word reaches A . Finally, since F is obtained by switching from $\text{Can}(\delta)$, it is a LR-tableau by Proposition 16. This justifies the third application of ρ_1 and completes the proof of the lemma.

5.3.5 Proof of Lemma 5

Let $A \in \text{YT}(\lambda/\mu, \mathbf{a})$. We have to show that $A^\nabla = \chi(A)$. For this we will use the following way of computing $\xi^N(D)$ for a tableau D : Write $D = E \star F$, where E has integers $1, \dots, l$, and F has integers $l+1, \dots, l+k$. First compute $\xi(E)$; then relabel the entries of F by subtracting l from them, and compute $(F', E^\circ) = \zeta(\xi(E), F)$. Finally, compute $F^\circ = \xi(F')$, and relabel the entries of E° by adding k to them. We obtain $\xi(D) = F^\circ \star E^\circ$. This follows immediately from relations (\otimes) in Section 3.1. Now $B^\circ = \xi^N(B)$ is computed as follows: Observe that $\xi^N(C^\circ) = C$, let $(A', C') = \zeta(C, A)$. Then, up to relabelling of C' , we have $B^\circ = \xi^N(A') \star C'$. By relation (\boxtimes) , we have $A^{\circ\circ} = A'$. Thus $B^{\circ\circ} = A' \star C'$. Finally, B^∇ is obtained by taking $(C'', A'') = \zeta(\xi^N(A'), C')$, and computing $\xi^N(C'')$. Since $C'' = C$, $\xi^N(C'') = C^\circ$. Thus, up to relabelling, $A^\nabla = A''$. We claim that $A'' = \chi(A)$. Recall that by definition of the reversal map χ , the image $\chi(A)$ is the second component of $\zeta(\xi(A'), C')$. This implies the result.

5.3.6 Proof of Lemma 6

Let $\mu = (\mu_1, \dots, \mu_\ell)$, $k := \ell + 1$, and set $\mu_k = 0$. Compute $a_{1,r} := \mu_{k-r} - \mu_{k-r+1}$, for all $1 \leq r \leq \ell$, and $a_{i,j} := a_{1,j-i+1}$, for all $1 \leq i \leq j \leq \ell$. It is easy to see that $(a_{i,j})$ is the recording matrix of the desired tableau $A = \xi(\text{Can}(\mu))$.

5.4 Proof of theorems

5.4.1 Proof of Theorem 1

As we showed in Section 4 (see Section 4.14 and Corollary 3), all the maps listed in Theorem 1 are linearly equivalent. To prove the second part of the theorem, let us summarize all linear reductions in Figure 14. Here we draw an arrow for every linear reduction given by a ps-circuit \mathfrak{J} , and place the cost of the circuit $\mathbf{s}(\mathfrak{J})$ above the arrow. We do not to write the cost above trivial (cost 1) circuits.

Recall the second part of Composition Lemma which claims that one needs to take a product of costs when taking a composition of linear reductions. Now observe that from each map in the diagram one can go to any other map (taking arrows in the reverse direction) so that the product never exceeds 36. This product maximizes when going from ρ_1 to χ . The verification is straightforward and left to the reader.

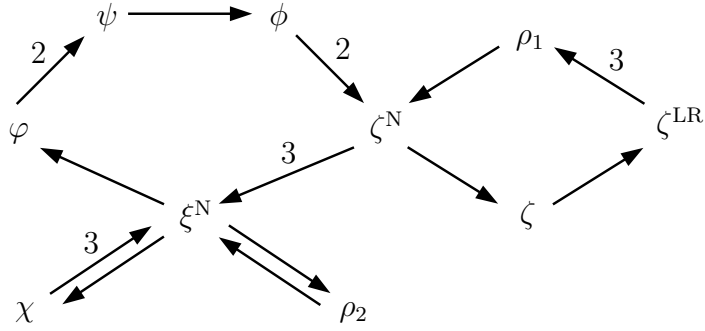

Figure 14: Diagram of linear reductions.

5.4.2 Proof of Theorem 2

Consider the map ξ . By Proposition 1, it can be computed at a cost of $\binom{k}{2}$ BK-transformations. Each BK-transformation is a piecewise linear map which can be computed at a cost of $O(k)$ additions and max / min operations on integers $a_{i,j}$. Note that the size of integers $a_{i,j}$ never exceed λ_1 , so during and after all BK-transformations they have bit-size $O(\log m)$. Therefore, the total cost of computing ξ is $O(k^3 \log m)$, as in the theorem. Also, by definition ξ is a size-neutral map (see Section 1.3).

By Theorem 1, all other maps are linearly reducible to ξ^N . Denote by α any of the remaining maps in Theorem 2, and by \mathfrak{J} denote a ξ^N -based ps-circuit computing α (at a cost at most 36). Recall that ξ^N and all linear cost maps are size-neutral (see Section 2.1), which makes map α size-neutral as well. Thus, the cost of computing any of the (at most 36) maps ξ^N is $O(k^3 \log m)$, where parameters k and $\log m$ are linear in the input parameters as in Theorem 2. Therefore, the total cost of computing α following \mathfrak{J} is $O(k^3 \log m)$, as desired.

6 Further bijections

6.1 Third Fundamental Symmetry map

Here we present another Fundamental Symmetry map ρ_3 , defined in [2, 3]. The definition in these papers is somewhat convoluted so we restate it here for the sake of clarity.

Start with LR-tableau $A \in \text{LR}(\lambda/\mu, \nu)$. Fill shape $[\mu]$ with zeros. We remove rows one by one, beginning with the bottom row. In each row to be removed, build a chain of integers in previous rows, starting with the last element and going to the first element. For each such element x , find the largest element $y < x$ in the previous row, not used

by the previous chains (starting from row containing x), then the largest element $z < y$ in the row above that of y not used by the previous chains, etc. Now replace y with x , z with y , etc. unless the integer k goes in $< k$ -th row; stay put in that case. Note that each zero forms a chain of length 1.

Denote by $v_{i,j}$ the number of chains of length $(i - j + 1)$ which start from i -th row. Let $B \in \text{YT}(\lambda/\nu, \mu)$ be a Young tableau corresponding to recording matrix $V = (v_{i,j})$. We claim that B is a LR-tableau, and define $B = \rho_3(A)$.

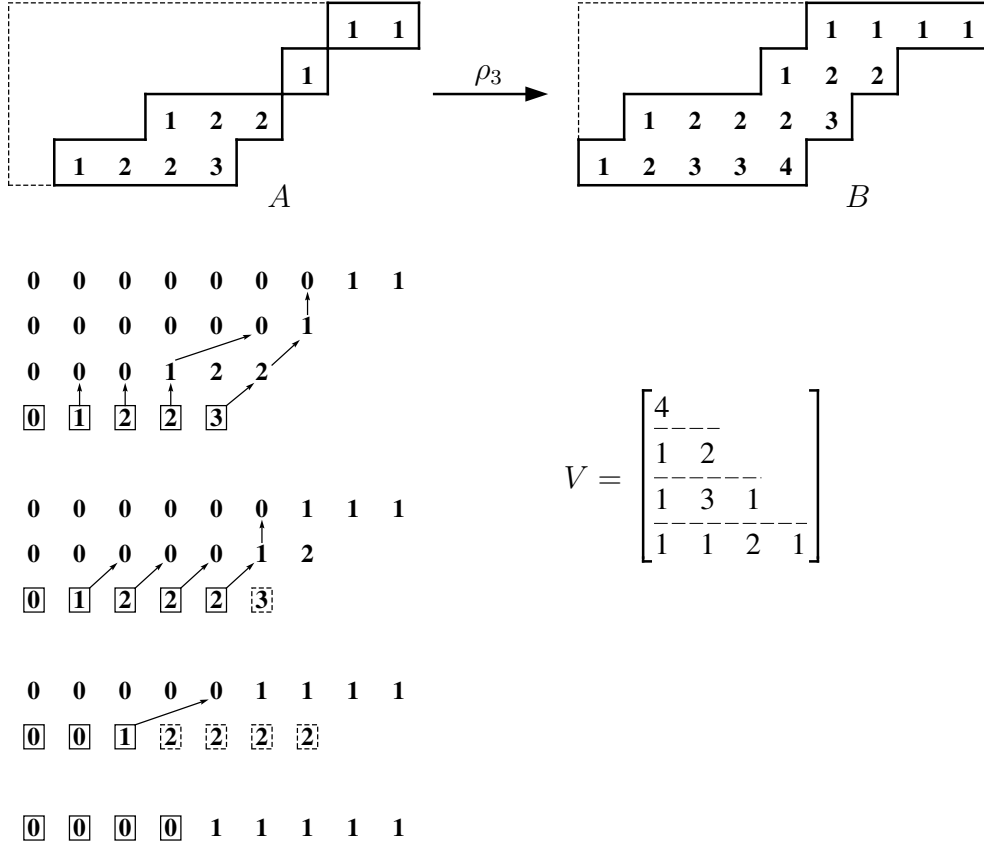

Figure 15: An example of the map $\rho_3 : A \rightarrow B$, where $A \in \text{LR}(\lambda/\mu, \nu)$, $B \in \text{LR}(\lambda/\nu, \mu)$, and $\lambda = (9, 7, 6, 5)$, $\mu = (7, 6, 3, 1)$, $\nu = (5, 4, 1)$. There is one chain of length 4, 3, 1, and two chains of length 2, starting from the 4-th row (see 4-th row of V).

Conjecture 1. *The Fundamental Symmetry maps ρ_1 , ρ_2 , ρ_2' and ρ_3 are identical.*

The conjecture is supported by numerical evidence. Also, in [3, §5] it was shown that $(\rho_3)^2 = 1$ by an involved argument. If established, the conjecture would simplify

the proof of Theorem 1 and further emphasize the importance of the fundamental symmetry.

6.2 Inverse maps

Recall that maps φ and ϕ are one-to-one.

Conjecture 2. *The RSK map φ and the Littlewood-Robinson map ϕ are linearly equivalent to their inverses.*

Let us emphasize here the need to distinguish between direct and inverse maps. It is a well known and studied phenomenon in Cryptography that some maps are easily computed, while their inverses are not; taking powers over the finite field vs. taking discrete logarithm being the most celebrated example. The conjecture above says there is no such problem with Young tableau maps and all Young tableau bijections are linearly equivalent to their inverses. Note that Schützenberger involution, Tableau Switching, Reversal and the First Fundamental Symmetry maps are *equal* to their inverses (\bowtie), and if Conjecture 1 holds so is the Second Fundamental Symmetry map. Thus the problem makes sense only for RSK and Littlewood-Robinson maps, as in the conjecture.

6.3 Octahedral map

Suppose four partitions λ, μ, ν , and τ satisfy $|\tau| = |\lambda| + |\mu| + |\nu|$. The *Octahedral map* is a one-to-one correspondence:

$$\varsigma : \bigcup_{\sigma \vdash |\lambda| + |\mu|} \text{LR}(\sigma/\lambda, \mu) \times \text{LR}(\tau/\sigma, \nu) \longrightarrow \bigcup_{\pi \vdash |\mu| + |\nu|} \text{LR}(\pi/\mu, \nu) \times \text{LR}(\tau/\lambda, \pi).$$

A bijection of this type was introduced in [25], in the equivalent language of hives, as a tool for a new proof of the LR-rule. This is defined using an *octahedral recurrence* considered earlier in connection with the enumeration of alternating sign matrices [34], and has recently appeared in other context [19, 42, 46].

As it was the case with the Littlewood-Robinson map, the existence of any such bijection ς will suffice in the proof of the LR-rule given in [25]. So, we will define an alternative version of the octahedral map using the tableau switching map ζ . From our point of view, this has the advantage that the definition given here yields the reduction $\varsigma \hookrightarrow \zeta$.

We define an Octahedral map ς as follows: Let $A \in \text{LR}(\sigma/\lambda, \mu)$, $B \in \text{LR}(\tau/\sigma, \nu)$. Consider $(A', C') = \zeta(\text{Can}(\lambda), A)$; since A is a LR tableau, $A' = \text{Can}(\mu)$ and $C' \in$

$\text{LR}(\sigma/\mu, \lambda)$. Next, let $(B', C''') = \zeta(C', B)$. Again, since switching preserves the property of being a Littlewood-Richardson tableau, there is some partition π of $|\mu| + |\nu|$, such that $B \in \text{LR}(\pi/\mu, \nu)$ and $C''' \in \text{LR}(\tau/\pi, \lambda)$. Finally, let $(C''', D) = \zeta(\text{Can}(\pi), C''')$. Thus, $C''' = \text{Can}(\lambda)$ and $D \in \text{LR}(\tau/\lambda, \pi)$. We define $\varsigma(A, B) = (B', D)$.

The following proposition is a consequence of (\boxtimes) .

Proposition 17. *The map ς defined above is a bijection.*

Corollary 4. *The Octahedral map ς is linearly reducible to Tableau Switching map ζ and other maps in Theorem 1.*

Note that ς is defined by a simple sequential circuit which uses the map ζ three times; thus $\varsigma \leftrightarrow \zeta$. Another way to prove this is to show first that ς is a composition of the LR-Tableau Switching map ζ^{LR} and the fundamental symmetry maps. Let us conclude this section with the following natural conjecture:

Conjecture 3. *The map ς and the map defined in [25] are identical and linearly equivalent to maps in Theorem 1.*

We should mention that the connection between Tableau Switching map ζ and the Octahedral map in [25] follows from [18] through linear equivalence with the Jeu de Taquin map ψ . Also, it was shown in [19] that in a special case the map ς gives a (another version) fundamental symmetry map (see the ‘‘commutor’’ in Section 5.2 of [19]). It is natural to conjecture that this fundamental symmetry map coincides with ρ_1 as well.

6.4 Burge correspondence

Let $\tilde{\varphi}$ denote the *Burge correspondence* [9] (see also [12, A4.1]). Numerically, it defines a one-to-one map between the same sets as the RSK map φ :

$$\tilde{\varphi} : \text{Mat}(\mathbf{a}, \mathbf{b}) \longrightarrow \bigcup_{\lambda \vdash N} \text{YT}(\lambda, \mathbf{b}) \times \text{YT}(\lambda, \mathbf{a})$$

This bijection is related to RSK correspondence in the following way. Let $V = (v_{i,j})$; denote $V^\downarrow := (v_{k+1-i,j})$ and $V^\leftrightarrow := (v_{i,k+1-j})$. Let $\varphi(V) = (B, A)$. Then, since column insertion commutes with row insertion [12, A2], we have that $\tilde{\varphi}(V^\downarrow) = (B, *)$ and $\tilde{\varphi}(V^\leftrightarrow) = (*, A)$. Thus $\varphi \leftrightarrow \tilde{\varphi}$ and this is done by a $\tilde{\varphi}$ -based simple parallel circuit which uses $\tilde{\varphi}$ twice. Similarly, one can show that $\tilde{\varphi} \leftrightarrow \varphi$, which implies $\varphi \sim \tilde{\varphi}$.

6.5 Hillman-Grassl map

Let $\lambda \vdash n$ be a fixed partition, $\ell = \ell(\lambda)$, $m = \lambda_1$. For every function $F : [\lambda] \rightarrow \mathbb{Z}_{\geq 0}$ and every $-\ell < c < m$, define *diagonal sums*

$$\alpha_c(F) = \sum_{(i,j) \in [\lambda], j-i=c} F(i,j),$$

and *rectangular sums*

$$\beta_c(F) = \sum_{i=1}^{i_c} \sum_{j=1}^{j_c} F(i,j),$$

where (i_c, j_c) is the last square on the diagonal $j - i = c$. Now, let $\mathbf{d} = (d_{1-\ell}, \dots, d_{m-1})$ be a nonnegative integer array. Define $\mathcal{B}_{\mathbf{d}}$ to be sets of all nonnegative integer functions F as above, such that $\beta_c(F) = d_c$, for all $-\ell < c < m$. Similarly, define $\mathcal{A}_{\mathbf{d}}$ to be sets of all reverse plane partitions of shape λ , such that $\alpha_c(F) = d_c$, for all $-\ell < c < m$.

The *Hillman-Grassl* (HG) *bijection* defines a one-to-one map $\vartheta_{\lambda} : \mathcal{B}_{\mathbf{d}} \rightarrow \mathcal{A}_{\mathbf{d}}$ [20] (see also [13, 15, 29]). It is easy to check that when $\lambda = (k^k)$ the set $\mathcal{B}_{\mathbf{d}}$ coincides with $\text{Mat}(\mathbf{a}, \mathbf{b})$ for certain \mathbf{a}, \mathbf{b} , while $\mathcal{A}_{\mathbf{d}}$ corresponds to pairs of GT-patterns joined at the diagonal [29]. In [13, Thm. 10.2] Gansner showed that the map $\vartheta_k := \vartheta_{\lambda}$ in this case coincides, up to a linear cost map, with the Burge correspondence $\tilde{\varphi}$. This immediately gives $\vartheta_k \sim \tilde{\varphi}$. Combining this equivalence with the one in the previous section we conclude that the HG-map in the “square case” is linearly equivalent to the RSK correspondence $\vartheta_k \sim \varphi$, as well as all other maps listed in Theorem 1. We omit the (easy) details.

For general shapes λ , given $F \in \mathcal{A}_{\mathbf{d}}$, set $k := \max\{m, \ell\}$, and fill with zeros the rest of the $k \times k$ square containing $[\lambda]$. Now apply RSK map φ to the resulting matrix. At the end, join at the diagonal the two GT-patterns of the resulting tableaux, and restrict this function to squares in $[\lambda]$ (see [29] for details). We leave it to the reader to show that this defines linear reduction $\vartheta_{\lambda} \hookrightarrow \varphi$, proving linear equivalence $\vartheta_{\lambda} \sim \varphi$ in general case, where λ is a part of the input.

To conclude, we note that the connection of ϑ with BK-transformations was observed in [29], where it was also shown that ϑ can be computed in $O(k^3 \log m)$, where $m = \max_c \{d_c\}$.

6.6 Other symmetry maps

Beside fundamental symmetry maps, there is a large number of “hidden” symmetries of Littlewood-Richardson coefficients $c_{\mu, \nu}^{\lambda}$. These symmetries form a finite group and were studied on a number of occasions (see [7]). As we mentioned above, a subgroup of index 2 of these symmetries can be given by linear cost maps [32]. Since the fundamental symmetry is a remaining generator, the symmetries outside this subgroup are given by maps which are all linearly equivalent to ρ_1 .

A different kind of symmetry map was given in [17] (see also [1, §3]):

$$\varrho : \text{LR}(\lambda/\mu, \nu) \longrightarrow \text{LR}(\lambda'/\mu', \nu'),$$

where λ' denotes the conjugate diagram (reflected across $i = j$ line). The bijections given in [17, 1] use a modified insertion map. It would be interesting to see whether this symmetry map is linearly equivalent to maps we consider in Theorem 1.

6.7 Schützenberger involution

Recall that we have not been able to show that the general Schützenberger involution ξ reduces to the other bijections appearing in this paper, while we were able to show that ξ^N and χ do. If ξ were not reducible to the other bijections this would mean that χ is a more natural extension of ξ^N to skew shapes than ξ . Recall [6, §5] that reversal is also more natural than Schützenberger involution from the point of view of dual equivalence. Proving that ξ is reducible to ξ^N remains an open problem.

7 Final Remarks

1. Note that we never attempted to give a lower bound on the complexity of the cost of tableau bijections. Since all constructions require $\theta(k^2)$ min-max operations, it is conceivable that such lower bound can be obtained by means of *Algebraic Complexity Theory* [10]. In other words, if one properly restrict the class of algorithms to consider, the lower bound $\Omega(k^3)$ might be attainable. Further investigation of this matter would be of great interest.

2. While the Octahedral map defined in [25] (see also [19]) looks extremely natural, it lacks formal and complete treatment in combinatorics literature. Our alternative version of this map and Conjecture 3 is a further indication of this. We would like to encourage the reader to further study this map and its connections to other combinatorial maps.

3. There are a score of other notable Young tableau bijections not mentioned in the paper. While some of these are based on some kind of insertion/evacuation procedures and thus seem strongly related to the maps we study, others are of a different nature. Examples of the first type include Lascoux-Schützenberger action of S_m on $\text{YT}(\lambda/\mu; m)$, RSK for shifted and super tableaux, etc. Examples of the second type include the Novelli-Pak-Stoyanovskii's bijection, and nonintersecting paths arguments. We refer to [12, 36, 43] for definitions and references. It would be nice to place these maps into our framework and perhaps even introduce some kind of complexity style hierarchy on them.

4. In [6] the authors present an important characterization of the tableau switching through its natural properties. In principle, one can use our linear reductions to obtain similar characterizations of the fundamental symmetry maps. We challenge the reader to make such a characterization explicit. This could lead to a positive resolution of Conjecture 1 and give a better understanding of the subject.

5. It was noted in [29] that the Hillman-Grassl map extends to real-valued functions and is given by a continuous piecewise-linear volume-preserving map in this case. Similar observations were made for other sets of Young tableaux and other tableau bijections (see e.g. [2, 7, 22, 32]). One can check that most of our linear reductions also extend to real-valued tableaux, and our linear cost maps are in fact (the usual, geometric) linear maps. Thus, one “real extension” suffice to establish the others. We leave further exploration of this subject to the interested reader.

6. We make no effort to optimize the constant 36 in the proof of Theorem 1. In fact, if $\rho_1 = \rho_2$ as Conjecture 1 suggests, this constant immediately drops down to 12. We wanted to emphasize the existence of such a constant, and would be just as happy if it worked out to be around 200, as in the first draft of the paper.

The idea to study the cost as the number of “large operations” is well-known in Computer Science literature. It was rejected for the purposes of Cryptography after A. Shamir showed in [41] that factoring has a polynomial cost algorithm in the number of arithmetic operations (of possibly very large integers). In our situation, all maps are size-neutral, so this problem never arises. Still, we should warn the reader that the constant implied by the $O(\cdot)$ notation in Theorem 2 is much larger than 36.

7. It was noticed in [31] that there is a certain uniqueness behind the linear cost partition bijections. This method was later used in [32] to obtain several linear cost LR-symmetry maps. We wonder if there is an “automatic” procedure to define the maps in Theorem 1. Even a framework for that would be of great interest.

8. We conclude by saying that even though we were able to formalize the connections between Young tableau bijections, this is important on a computational and perhaps philosophical level, but is hardly an “explanation from the Book”. We firmly believe that the real underlying structure behind these connections lies in the study of canonical bases in representation theory of symmetric and full linear groups.

Acknowledgements

We are grateful to Olga Azenhas, Arkady Berenstein, Andre Henriques, Leonid Levin, Ezra Miller, Richard Stanley and Terry Tao for interesting conversations and helpful remarks. Special thanks to David Jackson for reading and editing the previous version of the paper and his meticulous attention to details.

The first author was supported by the NSA and the NSF. Part of this work was done during second author's sabbatical stay at MIT Mathematics Department. The second author would like to thank CONACYT and DGAPA-UNAM for financial support, and to Richard Stanley for his support in the realization of the visit. The second author was also partially supported by DGAPA-UNAM IN111203. The first author would also like to thank the second author for organizing his visit to Mexico, where this work was continued.

References

- [1] O. Azenhas, The admissible interval for the invariant factors of a product of matrices, *Linear and Multilinear Algebra* **46** (1999), 51–99.
- [2] O. Azenhas, Littlewood-Richardson fillings and their symmetries, in *Matrices and Group Representations*, Textos de Matemática, Série B **19** (1999), Depto. de Matemática, Univ. de Coimbra, 81–92.
- [3] O. Azenhas, On an involution on the set of Littlewood-Richardson tableaux and the hidden commutativity, preprint, 2000, available from <http://dingo.mat.uc.pt/~cmuc/publicline.php?lid=1>
- [4] A. Barvinok and S. Fomin, Sparse interpolation of symmetric polynomials, *Adv. Appl. Math.* **18** (1997), 271–285.
- [5] E. A. Bender and D. E. Knuth, Enumeration of plane partitions, *J. Combin. Theory*, Ser. A **13** (1972), 40–54.
- [6] G. Benkart, F. Sottile and J. Stroomer, Tableau switching: algorithms and applications, *J. Combin. Theory*, Ser. A **76** (1996), 11–43.
- [7] A. D. Berenstein and A. Zelevinsky, Triple multiplicities for $sl(r+1)$ and the spectrum of the exterior algebra of the adjoint representation, *J. Algebraic Combin.* **1** (1992), 7–22.
- [8] A. Buch, The saturation conjecture (after A. Knutson and T. Tao), *Enseign. Math.* **46** (2000), 43–60.
- [9] W. H. Burge, Four correspondences between graphs and generalized Young tableaux, *J. Combin. Theory*, Ser. A **17** (1974), 12–30.
- [10] P. Bürgisser, M. Clausen and M. A. Shokrollahi, *Algebraic Complexity Theory*, Grundlehren der mathematischen Wissenschaften, Vol. 315, Springer, Berlin, 1997.
- [11] C. Carré, The rule of Littlewood-Richardson in a construction of Berenstein-Zelevinsky, *Internat. J. Algebra & Comput.* **1** (1991), 473–491.
- [12] W. Fulton, *Young Tableaux*, L.M.S. Student Texts 35, Cambridge U. Press, 1997.

- [13] E. R. Gansner, Matrix correspondences of plane partitions, *Pacific J. Math.* **92** (1981), 295–315.
- [14] M. R. Garey and D. S. Johnson, *Computers and intractability: A guide to the theory of NP-completeness*, Freeman, New York, 1979.
- [15] R. M. Grassl and A. P. Hillman, Functions on tableau frames, *Discrete Math.* **25** (1979), 245–255.
- [16] M. D. Haiman, Dual equivalence with applications, including a conjecture of Proctor, *Discrete Math.* **99** (1992), 79–113.
- [17] P. Hanlon and S. Sundaram, On a bijection between Littlewood-Richardson fillings of conjugate shape *J. Combin. Theory, Ser. A* **60** (1992), 1–18.
- [18] A. Henriques and J. Kamnitzer, On the symmetric monoidal category constructed using the octahedral recurrence, preprint, 2003.
- [19] A. Henriques and J. Kamnitzer, The octahedron recurrence and gL_n crystals, *Proc. 16-th FPSAC Conf.*, Vancouver, BC, 2004, available from <http://www-math.mit.edu/~andrhenr/>.
- [20] A. P. Hillman and R. M. Grassl, Reverse plane partitions and tableau hook numbers, *J. Combin. Theory, Ser. A* **21** (1976), 216–221.
- [21] G. D. James and A. Kerber, *The Representation Theory of the Symmetric Group*, Encyclopedia of Mathematics and its Applications **16**, Addison-Wesley, Reading, Massachusetts, 1981.
- [22] A. N. Kirillov and A. D. Berenstein, Groups generated by involutions, Gelfand-Tsetlin patterns, and combinatorics of Young tableaux, *St. Petersburg Math. J.* **7** (1996), 77–127.
- [23] D. E. Knuth, Permutations, matrices and generalized young tableaux, *Pacific J. Math.* **34** (1970), 709–727.
- [24] D. E. Knuth, *The Art of Computer Programming*, vol. 3, *Sorting and Searching*, second ed., Addison-Wesley, Reading, Massachusetts, 1998.
- [25] A. Knutson, T. Tao and C. T. Woodward, A positive proof of the Littlewood-Richardson rule using the octahedron recurrence, arXiv:math.CO/0306274.
- [26] M. A. A. van Leeuwen, The Robinson-Schensted and Schützenberger algorithms, an elementary approach, *Electron. J. Comb.* **3** (1996), RP R15, 32 p.
- [27] M. A. A. van Leeuwen, The Littlewood-Richardson rule, and related combinatorics, in *Interaction of combinatorics and representation theory*, 95–145, *MSJ Mem.* **11**, Math. Soc. Japan, Tokyo, 2001.
- [28] I. G. Macdonald, *Symmetric functions and Hall polynomials*, second ed., Oxford University Press, Oxford, 1995.

- [29] I. Pak, Hook length formula and geometric combinatorics, *Sémin. Lothar. Comb.* **46**, B46f (2001), 13 pp.
- [30] I. Pak, Partition Bijections, a Survey, to appear in *Ramanujan Journal*, available from <http://www-math.mit.edu/~pak>.
- [31] I. Pak, Partition Identities and Geometric Bijections, *Proc. A.M.S.*, to appear, 2003.
- [32] I. Pak and E. Vallejo, Combinatorics and geometry of Littlewood-Richardson cones, to appear in *Europ. J. Comb.*, available from <http://www-math.mit.edu/~pak>.
- [33] C. H. Papadimitriou, *Computational Complexity*, Addison-Wesley, Amsterdam, 1994.
- [34] D. P. Robbins and H. Rumsey, Determinants and alternating-sign matrices. *Adv. Math.* **62** (1986), 169–184.
- [35] G. de B. Robinson, On the representations of the symmetric group, *Amer. J. Math.* **60** (1938), 745–760.
- [36] B. E. Sagan, *The symmetric group. Representations, combinatorial algorithms, and symmetric functions*, second ed., Graduate Texts in Mathematics **203**, Springer, New York, 2001.
- [37] C. Schensted, Longest increasing and decreasing subsequences, *Canad. J. of Math.* **13** (1961), 179–191.
- [38] M.-P. Schützenberger, Quelques remarques sur une construction de Schensted, *Math. Scand.* **12** (1963), 117–128.
- [39] M.-P. Schützenberger, Promotion des morphismes d’ensembles ordonnés, *Discrete Math.* **2** (1972), 73–94.
- [40] M.-P. Schützenberger, La correspondance de Robinson, in *Combinatoire et Représentation du Groupe Symétrique*, Lecture Notes in Math. **579**, Springer, 1977, 59–135.
- [41] A. Shamir, Factoring Numbers in $O(\log n)$ Arithmetic Steps, *Inf. Proc. Letters* **8** (1979), 28–31.
- [42] D. E. Speyer, Perfect Matchings and the Octahedron Recurrence, arXiv:math.CO/0402452.
- [43] R. P. Stanley, *Enumerative Combinatorics*, vol. 2, Cambridge Studies in Advanced Mathematics **62**, Cambridge University Press, 1999.
- [44] J. R. Stembridge, Computational aspects of root systems, Coxeter groups, and Weyl characters, in *Interaction of combinatorics and representation theory*, 1–38, *MSJ Mem.* **11**, Math. Soc. Japan, Tokyo, 2001.
- [45] G. P. Thomas, On a construction of Schützenberger, *Discrete Math.* **17** (1977), 107–118.
- [46] D. Thurston, From Dominoes to Hexagons, arXiv:math.CO/0405482.